

2014

Analysis of Risky and Aggressive Driving Behaviors among Adult Iowans

Yundi Huang
Iowa State University

Follow this and additional works at: <https://lib.dr.iastate.edu/etd>

 Part of the [Civil Engineering Commons](#)

Recommended Citation

Huang, Yundi, "Analysis of Risky and Aggressive Driving Behaviors among Adult Iowans" (2014). *Graduate Theses and Dissertations*. 13748.

<https://lib.dr.iastate.edu/etd/13748>

This Thesis is brought to you for free and open access by the Iowa State University Capstones, Theses and Dissertations at Iowa State University Digital Repository. It has been accepted for inclusion in Graduate Theses and Dissertations by an authorized administrator of Iowa State University Digital Repository. For more information, please contact digirep@iastate.edu.

Analysis of risky and aggressive driving behaviors among adult Iowans

by

Yundi Huang

A thesis submitted to the graduate faculty
in partial fulfillment of the requirements for the degree of
MASTER OF SCIENCE

Major: Civil Engineering (Transportation Engineering)

Program of Study Committee:
Konstantina Gkritza, Co-major Professor
Jing Dong, Co-major Professor
Frederick Lorenz

Iowa State University

Ames, Iowa

2014

Copyright © Yundi Huang, 2014. All rights reserved.

TABLE OF CONTENTS

LIST OF TABLES	v
LIST OF FIGURES.....	vii
ACKNOWLEDGEMENTS	x
ABSTRACT	xi
CHAPTER 1 INTRODUCTION	1
1.1 Motivation	1
1.2 Background.....	3
1.2.1 Overview of past studies	4
1.2.2 Research gap	5
1.3 Research Objectives	6
1.4 Thesis Structure	7
CHAPTER 2 LITERATURE REVIEW	8
2.1 Overview	8
2.2 Risky Driving Behavior.....	9
2.2.1 Non-use of safety belts.....	10
2.2.2 Drowsiness	12
2.2.3 Cell phone use.....	13
2.2.4 Driving while intoxicated/driving under influence (DWI/DUI).....	14
2.2.5 Aggressive driving	16
2.2.6 Other factors.....	16
2.3 Aggressive Driving behavior.....	16
2.3.1 Driving with aggression (DWA).....	18
2.3.2 Speeding.....	20
2.3.3 Red-light running (RLR).....	21
2.4 Risk Taking Theory	22
2.4.1 Risk homeostasis theory (RHT).....	22

2.4.2 Theory of reasoned action (TRA)	24
2.4.3 Theory of planned behavior (TPB)	27
2.4.4 Other theories	28
2.5 Theory Applications	29
2.6 Review of Literature	31
2.7 Summary	32
CHAPTER 3 METHODS	37
3.1 Overview	37
3.2 Sampling Procedures	37
3.2.1 Iowa telephone survey	38
3.2.2 Survey results	38
3.3 Data Measurements	39
3.3.1 Data recoding	39
3.3.2 Created indices	40
3.3.3 Dummy coding.....	49
3.4 Structural Equation Modeling (SEM).....	55
3.4.1 Model specification.....	56
3.4.2 Model estimation	59
3.4.3 Model evaluation	60
3.4.4 Model application	62
3.5 Summary.....	63
CHAPTER 4 DESCRIPTIVE RESULTS	65
4.1 Overview	65
4.2 Aggressive Driving Statistics	65
4.2.1 Speeding.....	65
4.2.2 Red-light running	70
4.2.3 Driving with aggression.....	71
4.3 Demographic and Socioeconomic Characteristics	73
4.3.1 Gender-oriented responses on aggressive driving behavior	73

4.3.2 Age-oriented responses on aggressive driving behavior.....	75
4.3.3 Socioeconomic, residential, and travel history on aggressive driving	77
4.4 Summary.....	80
CHAPTER 5 MODEL RESULTS, IMPLICATION, AND APPLICATION	81
5.1 Overview	81
5.2 Descriptive Statistics for Indices Used in Modeling	82
5.3 Conceptual Model Construction and Results	87
5.3.1 Univariate behavior models	90
5.3.2 Bivariate behavior models	94
5.3.3 Trivariate behavior models	97
5.4 Structural Equation Model Testing.....	119
5.4.1 Exploration of five trial models	119
5.4.2 Model limitation.....	129
5.5 Model Selection.....	130
5.6 Major Findings	131
5.6.1 Implications of major findings.....	131
5.6.2 Application.....	135
5.7 Summary.....	141
CHAPTER 6 CONCLUSIONS, LIMITATIONS, AND RECOMMENDATIONS.....	142
6.1 Overview	142
6.2 Conclusions	142
6.3 Limitations and Recommendations for Future Research	144
BIBLIOGRAPHY	149
APPENDIX A: COMPLETE SURVEY QUESTIONNAIRE AND RESULTS	160
APPENDIX B: OTHER RESULTS.....	189

LIST OF TABLES

Table 1-1: Annual Crashes by Crash Severity (NHSTA, 2009)	1
Table 2-1: Four Types of Human Errors Cited by the FMCSA (FMCSA, 2006).....	10
Table 2-2: Major Classes of Aggressive Behavior.....	18
Table 2-3: Summary of Review of Literature in Different Technology Adoption	31
Table 3-1: Descriptive Statistics After Recoding and the Reliability of the Indicators	42
Table 3-2: Inter-correlation Matrix of the Items Under Corresponding Questions.....	45
Table 3-3: Descriptive Statistics After Data Measurements	50
Table 5-1: Descriptive Statistics for Indices Used in Models	84
Table 5-2: Correlation Matrix of the Variables.....	85
Table 5-3: Descriptive Statistics of Variables for Males and Females	93
Table 5-4: Decomposition of Total Effects (t-statistics) for Males and Females.....	93
Table 5-5: Decomposition of the Effects for Bivariate Behavior Models.....	96
Table 5-6: Standardized Results for Path Coefficient (t-statistics) in Acceptance Model ...	100
Table 5-7: Standardized Results for Path Coefficient (t-statistics) in Permissiveness Model.....	104
Table 5-8: Fit Summary for Acceptance and Permissiveness models	105
Table 5-9: Fit Summary for Acceptance and Permissiveness Models with Gender Differences.....	110
Table 5-10: Standardized Results for Path Coefficient (t-statistics) in Demographic Acceptance Model	113
Table 5-11: Standardized Results for Path Coefficient (t-statistics) in Demographic Permissiveness Model	117

Table 5-12: Fit Summary for Demographic Acceptance and Permissiveness Models	118
Table 5-13: Standardized Results for Path List of 2A's Model	121
Table 5-14: Standardized Results for Path List of Acceptance Model	122
Table 5-15: Standardized Results for Path List of Permission Model	124
Table 5-16: Standardized Results for Path List of Combined Model	126
Table 5-17: Standardized Results for Path List of Permissiveness Model.....	128
Table 5-18: Correlation Among Latent Variables (t-statistics) in Permissiveness Model...	129
Table A-1: Public Opinions to the Identified 11 High-level Goals (adopted from Albrecht et al., 2013)	177

LIST OF FIGURES

Figure 1.1: Percentage of risky factors for drivers involved in fatal crashes in Iowa 2011	2
Figure 1.2: Percentage of fatal crashes involving potentially aggressive driver actions	4
Figure 2.1: Schematic representation of the TRA (Fishbein & Ajzen, 1975).....	25
Figure 2.2: Schematic representation of Ajzan’s TPB (adopt from Ajzan, 1991)	28
Figure 3.1: Example of path (flow) diagram with SEM symbolizations	56
Figure 4.1: Acceptance of speeding behavior on different road classifications.....	66
Figure 4.2: Driver’s experience with speeding in past 30 days.....	67
Figure 4.3: Perception of various speeding behaviors in the driver’s area	68
Figure 4.4: Reasons for speeding	69
Figure 4.5: Perceptions of various RLR behaviors	70
Figure 4.6: Perceptions of DWA.....	72
Figure 4.7: Attitudes towards speeding by gender.	74
Figure 4.8: Experience with RLR in past 30 days by gender.	74
Figure 4.9: Attitudes towards DWA by different age groups.	75
Figure 4.10: Perceptions of DWA by different age groups.....	76
Figure 4.11: Attitudes towards speeding by different VMT of the respondents	79
Figure 5.1: The proposed version of the TRA model.....	88
Figure 5.2: The total effects for DWA.	91
Figure 5.3: The total effects for speeding.....	91
Figure 5.4: The total effects for RLR.	91

Figure 5.5: Theoretical model of proposed relationships between perception, acceptance, and experience with DWA and speeding	94
Figure 5.6: Theoretical model of proposed relationships between perception, acceptance, and experience with DWA and RLR.....	95
Figure 5.7: Theoretical model of proposed relationships between perception, acceptance, and experience with speeding and RLR	95
Figure 5.8: Conceptual model of the proposed relationships between perception, acceptance, and experience with respect to each aggressive driving behavior of DWA, RLR, and speeding.....	102
Figure 5.9: Conceptual model of the proposed relationships between perception, permissiveness, and experience with respect to each aggressive driving behavior of DWA, RLR, and speeding.	103
Figure 5.10: Standardized Results for Path Coefficient (t-statistics) in Acceptance Model (Female and Male)	108
Figure 5.11: Standardized Results for Path Coefficient (t-statistics) in Permissiveness Model (Female and Male)	109
Figure 5.12: Conceptual model of the proposed relationships between perception, acceptance, and experience with respect to each aggressive driving behavior of DWA, RLR, and speeding, with taking age, gender, and VMT into consideration..	111
Figure 5.13: Conceptual model of the proposed relationships between perception, permissiveness, and experience with respect to each aggressive driving behavior of DWA, RLR, and speeding, with taking age, gender, and VMT into consideration.	116
Figure 5.14: A model predicting aggressive driving experience from perception and tolerance of aggressive driving.	120
Figure 5.15: Acceptance model predicting aggressive driving experience from perception and acceptance of aggressive driving.....	122
Figure 5.16: Permission model predicting aggressive driving experience from perception and permission of aggressive driving	124
Figure 5.17: Combined model predicting aggressive driving experience from perception, acceptance, and permission of aggressive driving	125

Figure 5.18: Permissiveness model predicting aggressive driving experience from perception and permissiveness towards aggressive driving	127
Figure B.1: The estimated path coefficients and t-statistics of each aggressive behavior for male	189
Figure B.2: The estimated path coefficients and t-statistics of each aggressive behavior for female	190
Figure B.3: Male's theoretical model of proposed relationships between perception, acceptance, and experience with DWA and speeding	191
Figure B.4: Male's theoretical model of proposed relationships between perception, acceptance, and experience with DWA and RLR	191
Figure B.5: Male's theoretical model of proposed relationships between perception, acceptance, and experience with speeding and RLR	191
Figure B.6: Female's theoretical model of proposed relationships between perception, acceptance, and experience with DWA and speeding	192
Figure B.7: Female's theoretical model of proposed relationships between perception, acceptance, and experience with DWA and RLR	192
Figure B.8: Female's theoretical model of proposed relationships between perception, acceptance, and experience with speeding and RLR	192
Figure B.9: The estimated permissive attitude path coefficient (t-statistics) and the decomposition of total effects for each aggressive behavior	193

ACKNOWLEDGEMENTS

First of all, I would like to thank my major professor, Dr. Konstantina Gkritza, for her support and contribution on the completion of this thesis. Secondly, I would like to thank my co-major professor, Dr. Jing Dong, for her role in supporting and encouraging me on the research. Lastly, I would like to give special thanks to my minor representative, Dr. Frederick Lorenz, for his immeasurable guidance and assistance throughout this whole study.

In addition, I would also like to thank my colleagues, the department faculty, and staff for making my time at Iowa State University a wonderful experience. I want to also offer my appreciation to those who were willing to participate in my surveys and observations, without whom, this thesis would not have been possible.

Finally, thanks to my friends for their help and to my family for their patients, care, and love.

ABSTRACT

In 2011 alone, risky and aggressive driving behaviors were reported as contributing factors for 43,668 drivers who have been involved in 29,757 fatal crashes in the U.S.; these behaviors have become a growing problem recently. To alleviate this problem, the exploratory research study was designed to examine the relationship of perception of, acceptance/permissiveness of, and experience with various risky and aggressive driving behaviors among adult Iowans. Past studies have recommended developing comprehensive research to analyze the aggressive behaviors from the perspective of transportation engineering. Therefore, a cell phone and landline questionnaire survey covering a wide range of traffic safety topics such as attitudes toward traffic safety policies, enforcement, activities, and driving experience was disseminated across the State in 2011. 1,088 respondents were eventually involved, and their perceptions, attitudes, and practices of aggressive driving behaviors including speeding, red-light running (RLR), and driving with aggression (DWA) were investigated.

Path analysis, which is a special case of Structural Equation Modeling (SEM) techniques, was used to estimate conceptual mediating models that were constructed based on a proposed version the theory of reasoned action (TRA). Mediating models for these three behaviors were analyzed from perception to experience through acceptance/permissiveness, where acceptance/permissiveness was the mediator. The results from several conceptual models indicated that the respondents held more tolerating attitudes towards speeding and DWA than towards RLR, and participants'

enhanced perceptions on the behaviors raised their experience with behaving aggressively both directly and indirectly through their accepting/permissive attitudes towards aggressive driving. Moreover, an individual's demographic characteristics and travel information were also examined to investigate the relationship between aggressive driving behaviors and driver's characteristics. The results showed that young male drivers were found more aggressive than female drivers and older age groups. In addition, several SEM structural models were also established and verified the results obtained from conceptual models.

This study provides valuable findings to engineers, policy makers, and companies with various interventions and applications, in a bid to improve driver's driving behaviors and the overall traffic safety in Iowa.

CHAPTER 1

INTRODUCTION

1.1 Motivation

Vehicle crashes are considered one of the most serious threats to public health. As shown in Table 1-1, more than 61 million crashes, in which vehicle drivers, pedestrians, and bicyclists were killed or severely injured (e.g., brain or spine cord injury, fractures, and concussion), occurred from 2000 to 2009 in the United States. The annual crashes were reported over 6 million, with slight decreases in 2008 and 2009. During this period, fatal crashes accounted for 0.6% of the total crashes and resulted in about 0.4 million deaths. In recent years, 33,561 people have died in motor vehicle traffic crashes in 2012, compared to 32,479 in 2011, according to NHTSA data compiled in 2013. With the increase in crashes and the resulting fatalities and injuries, the World Health Organization has projected that road traffic deaths and injuries rank will third among all causes of death and disability worldwide by 2020 (WHO, 2003).

Table 1-1: Annual Crashes by Crash Severity (U.S. National Highway Safety Traffic Administration, Traffic Safety Facts, 2009)

Item	2000	2001	2002	2003	2004	2005	2006	2007	2008	2009
Crash	6,39	6,32	6,316	6,328	6,181	6,15	5,973	6,02	5,81	5,50
(1,000)	4	3				9		4	1	5
Fatal	37.5	37.9	38.5	38.5	38.4	39.3	38.6	37.4	34.2	30.8
Injury	2,07	2,00	1,929	1,925	1,862	1,81	1,746	1,71	1,63	1,51
PDO	0	3	4,348	4,365	4,281	6	4,189	1	0	7
	4,28	4,28				4,30		4,27	4,14	3,95
	6	2				4		5	6	7
Percent										
Fatal	0.6	0.6	0.6	0.6	0.6	0.6	0.6	0.6	0.6	0.6
Injury	32.4	31.7	30.5	30.4	30.1	29.5	29.2	28.4	28.1	27.6
PDO	67.0	67.7	68.8	69.0	69.3	69.9	70.1	71.0	71.4	71.9

Human error and inappropriate driving behaviors accounted for more than 90% of road crashes (NHTSA, 2001). Aggressive driving is a contributing factor for annual crashes occurred in the U.S. that about 13,000 fatalities or injuries were reported as resulting from risky and aggressive driving behaviors since 1990, according to the 1997 statistics from NHTSA and the American Automobile Association.

In 2011 alone, 29,757 fatal crashes in the U.S. led to around 32,479 fatalities and more than 2.22 million injuries, among which risky driving behaviors were reported as contributing factors for 43,668 drivers. In the state of Iowa specifically, 360 deaths were reported in 329 fatal crashes in 2011 and 473 drivers involved in these fatal crashes were directly engaged in risky and aggressive driving (FARS, 2011). The percentages of risky factors for drivers involved in fatal crashes in Iowa in 2011 are presented in Figure 1.2.

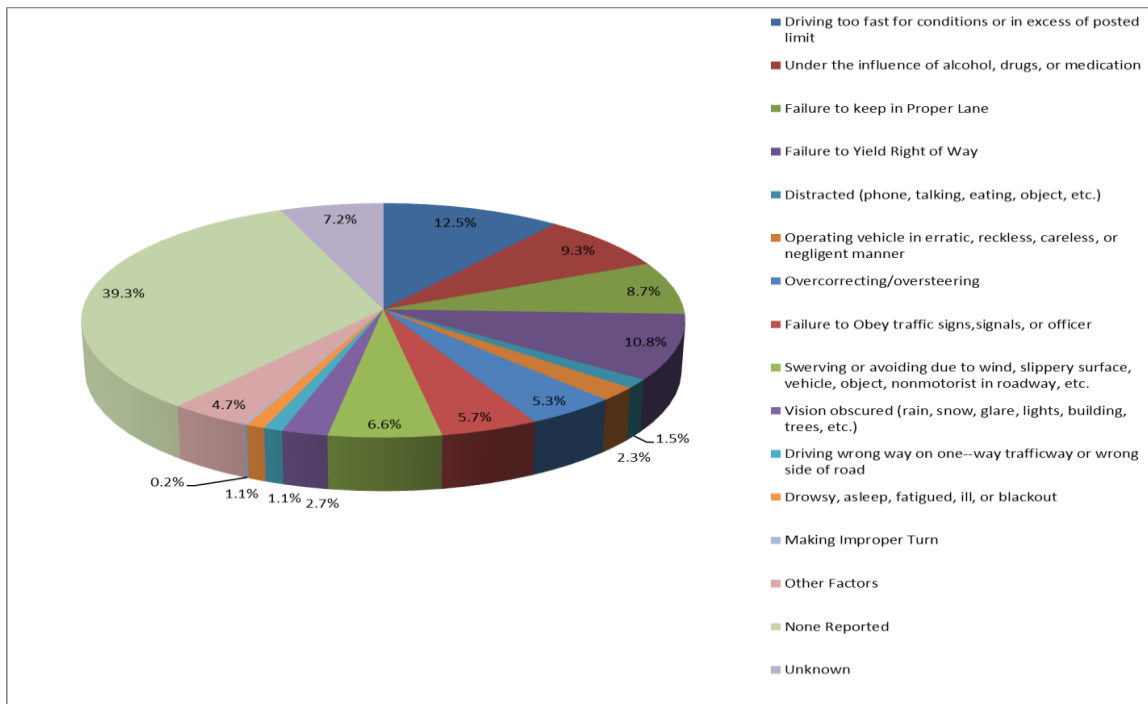

Figure 1.1 Percentage of risky factors for drivers involved in fatal crashes in Iowa in 2011 (NHTSA, 2011)

These alarming statistics on risky and aggressive driving behaviors causing fatalities among Iowa drivers provides motivation to conduct an in-depth study of the current state related to risky and aggressive driving in Iowa. Specifically, this study examines the relationship of perceptions, accepting/permissive attitudes, and behaviors of various aggressive driving behaviors among adult Iowans.

1.2 Background

In 2002, the National Highway Traffic Safety Administration (NHTSA) conducted a survey on speeding and unsafe driving behaviors. The results showed that nearly half (40%) of drivers admitted that they “sometimes” have entered an intersection just as the light turned from yellow to red, and 11% reported doing so “often.” Moreover, one out of ten (10%) admitted “sometimes” cutting in front of another driver, and 2% reported doing so “often.” In the same survey, one-third (34%) reported feeling threatened by other drivers a few times in a month (NHTSA, 2004). Therefore, it can be seen that risky and aggressive driving behavior is not uncommon in the current society.

In 2008, the AAA Foundation for Traffic Safety conducted a nationwide survey on driver’s attitudes, behaviors, knowledge, and opinions of traffic safety. The results indicated that approximately 56% of fatal crashes involved one or more aggressive driving actions, typically at an excessive speed (AAA Foundation for Traffic Safety, 2009). The AAA Foundation for Traffic Safety has reported the role of aggressive driving in fatal crashes based on 191,611 fatal crashes that involved 289,659 drivers and resulted in 212,427 deaths from 2003 through 2007. Figure 1.3 shows the percentage of fatal crashes involving potentially aggressive actions. As shown, speeding (30.7%) is the

leading factor of fatal crashes, followed by the failure to yield right of way (11.4%). In addition, reckless driving (7.4%), violating the rule of traffic controls (6.6%), and making improper turn (4.1%) are also major causes for the fatalities. Thus, aggressive driving behavior has become a serious threat to public health.

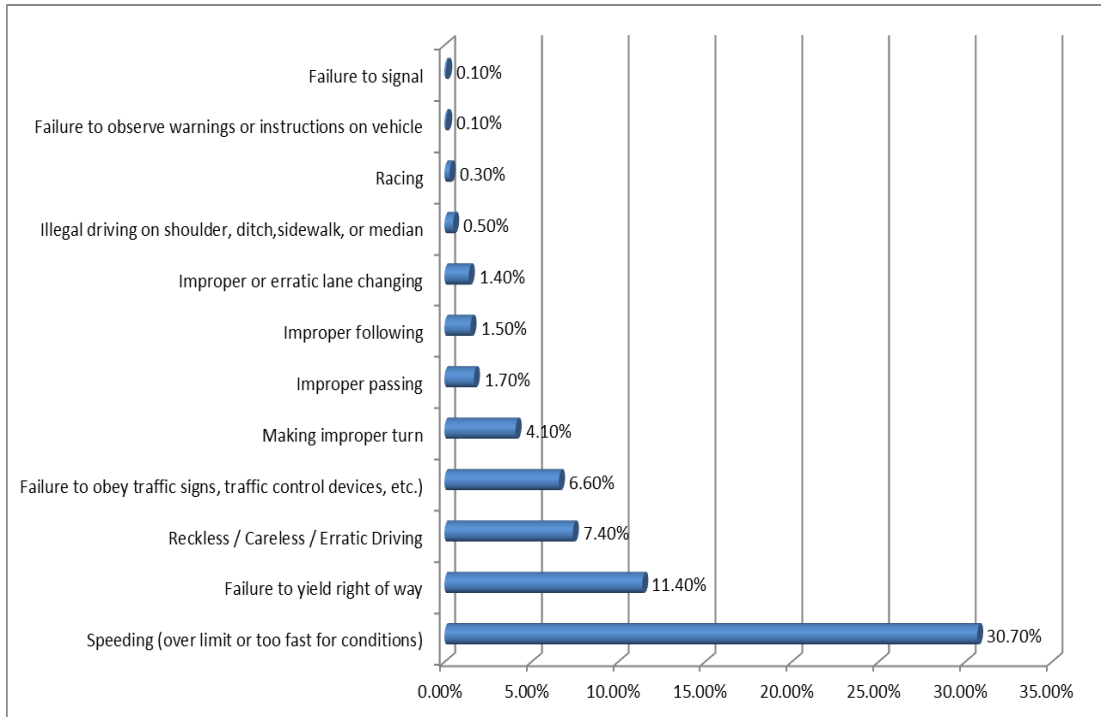

Figure 1.2 Percentage of fatal crashes involving potentially aggressive driver actions (FARS 2003 – 2007)

1.2.1 Overview of past studies

Various risky driving behaviors, including non-use of safety belts, drowsiness, cell phone use, Driving While Intoxicated/Driving Under the Influence (DWI/DUI), and aggressive driving have been studied in past research. Aggressive driving, one of the most prominent risky behaviors, was defined as a more “intentional” or “hostile” driving behavior that imperils road users and property than other risky driving behaviors

(NHTSA, 2000). Various triggers for aggression, both environmental and personal, have resulted in severe fatal crashes and become a growing worldwide problem. Previous studies have evaluated the relationship between anger (Lajunen and Parker, 2001; Millar, 2007; Nesbit et al., 2007 & 2012; Wickens et al., 2011; Berdoulat et al., 2013) or personality traits (Chliaoutakis et al., 2002; Miles and Johnson, 2003; Benfield et al., 2007; Constantinou et al., 2011; Jovanovic et al., 2011; Dahlen et al., 2012; Berdoulat et al., 2013) and aggressive driving. Drivers' motivations and various socio-demographic, environmental and trip-related characteristics have been also assessed in a substantial number of studies. However, what remains to be studied are the relationship among each aggressive driving behavior, and adult Iowan's perceptions of, attitudes towards, and experience with these behaviors.

1.2.2 Research gap

Past studies (Chliaoutakis et al., 2002; Miles & Johnson, 2003; Benfield et al., 2007; Constantinou et al., 2011; Jovanovic et al., 2011; Dahlen et al., 2012; Berdoulat et al., 2013) were conducted to determine the influence of driver's personality traits (i.e., impatient, completive, impulsiveness, sensation seeking, risk taking, aggressive disposition and hostile) and cognitive factors on aggressive behaviors through the frustration-aggression hypothesis, a theory stating that aggression is the result of blocking, frustrating, and an individual's efforts to attain a goal (Friedman & Schustack, 1999). Most of these researches focused on the impacts of psychological factors, such as driving anger, aggressiveness, and impulsiveness, on aggressive driving. However, the definition of "aggressive driving" is still ambiguous, and the behaviors are difficult to

measure accurately. NHTSA reported that two-thirds of traffic fatalities involved behaviors commonly associated with aggressive driving such as speeding, red-light running, and improper lane changes (NHTSA, 2001a), and such behaviors have not been integrated and analyzed simultaneously, nor have risky behaviors such as horn-honking or tailgating. This thesis will examine the relationship among driver's attitudes, perceptions, and practices of the identified aggressive behaviors—speeding, red-light running (RLR), driving with aggression (DWA)—rather than driver's personality (e.g., openness, and neuroticism) and emotions (e.g., anger and impulsiveness).

1.3 Research Objectives

As risky and aggressive driving behaviors have become a growing problem and serious threat to public health, the research objectives of this thesis are to:

- Investigate the behaviors of various risky and aggressive driving among adult Iowans based on a statewide public opinion survey conducted in 2011;
- Examine the relationship among perception of, acceptance/permissiveness of, and experience with aggressive driving behaviors including speeding, RLR, and DWA through statistical models;
- Explore the differences of aggressive driving behaviors across demographic groups such as age, gender, and Vehicle Miles Traveled (VMT);

in a bid to propose recommendations for targeted interventions to improve Iowans' driving behaviors, and therefore, improve the overall traffic safety in Iowa.

1.4 Thesis Structure

To achieve the research objectives presented above, this thesis will apply psychology theories of a variant on the Theory of Reasoned Action (TRA) and estimate statistical models through path analysis, which is a special case of the Structure Equation Models (SEM). This thesis follows the structure below and consists of six chapters:

Chapter 1: The *Introduction* presents the motivation, background, objective, and structure of this thesis on aggressive driving behaviors.

Chapter 2: The *Literature Review* shows an overview of various risky and aggressive driving behaviors and risk-taking theories, as well as a review of past studies on risky and aggressive driving behaviors.

Chapter 3: The *Method* briefly discusses the design and results of a public opinion survey, and then, in detail, provides procedures associated with the sampling and measurement of data used in the analysis. The methodology applied to analyze the data is presented as well.

Chapter 4: The *Descriptive Results* provides the detailed descriptive results of the responses to aggressive driving-related questions from the public opinion survey questionnaire.

Chapter 5: The *Model Results and Major Findings* chapter includes the estimation results and implications of findings from various conceptual models based on the proposed version of the TRA using SEM techniques.

Chapter 6: The *Conclusions, Limitations, and Recommendations* chapter offers concluding remarks, limitations, and some recommendations for future research.

CHAPTER 2

LITERATURE REVIEW

2.1 Overview

Because human errors such as risky driving behaviors are significant contributors to vehicle crashes, improving an individual's driving behaviors and minimizing driving risks would reduce vehicle crashes and improve traffic safety. National and international studies have reported that risky driving behaviors, including not wearing safety belts, drowsy driving, driving while intoxicated/driving under the influence (DWI/DUI), cell phone use while driving, and aggressive driving, have resulted in traffic violations and vehicle crashes. Specifically, aggressive driving is one very risky driving behavior, and is considered a major problem in the U.S. (American Automobile Association, 1998; National Highway Traffic Safety Administration, 1999). Aggressive driving behaviors studied in this research project included driving with aggression (DWA), red-light running (RLR), and speeding. To address this problem, a variety of theories for taking risk, such as Risk Homeostasis Theory (RHT), Theory of Reasoned Action (TRA), and Theory of Planned Behavior (TPB), were developed to analyze and predict the risky driving behavior of drivers. Among these theories, the TRA has been widely used in analyzing driving behaviors and provides the basis for this study. The application of TRA on transportation safety is discussed in detail in this chapter.

This chapter investigates the definition and various behaviors of risky and aggressive driving, as well as different risk-taking theories, and then provides a review

of national and international studies on the issue of risky and aggressive driving behaviors.

2.2 Risky Driving Behavior

Risky driving behavior is not uncommon in contemporary society and is a vital threat to public health. In fact, in 2011, 29,757 fatal crashes in the U.S. led to around 32,479 fatalities and more than 2.22 million injuries, among which risky driving behaviors were reported as contributing factors for 43,668 drivers (NHTSA, 2011). In the state of Iowa specifically, 360 deaths were reported in 329 fatal crashes in 2011, and 473 drivers involved in these fatal crashes were directly engaged in risky and aggressive driving (FARS, 2011). However, drivers had changed their behavior slightly while driving, such as using their safety belts, the fatalities were estimated to have been reduced to 10,414 in 1996 alone and 90,425 from 1975-1998, according to statistic compilations by NHTSA in 1998.

Among the 85% to 95% of human errors contributing to vehicle crashes (NHTSA, 2001), the Federal Motor Carrier Safety Administration (FMCSA, 2006) cited four types of human errors causing the crashes as presented in Table 2-1. From the table it can be seen that decision errors occurred the most frequently (38.0%), followed by recognition errors (28.4%). Performance errors (9.2%), however, did not account for much of the total human errors. The report indicated that errors of speeding and distraction were the most common.

Table 2-1: Four Types of Human Errors Cited by the FMCSA (FMCSA, 2006)

Type	Occupation	Example
Decision Errors	38.0%	Driver drove too fast for conditions
Recognition Errors	28.4%	Driver did not recognize the situation due to not paying proper attention
Non-performance Errors	11.6%	Driver fell asleep
Performance Errors	9.2%	Driver exercised poor directional control

Based on these four types of errors, researchers have identified various risky driving behaviors such as not wearing safety belts/helmets, drowsy driving, frequent cell phone use, driving under the influence of alcohol/drugs, and aggressive driving. Other less frequent behaviors involve thrill-seeking, driving with a risky perception, inexperienced driving skills, driving under stress, unlicensed driving, and the influence of passengers.

2.2.1 Non-use of safety belts

Safety belts are also known as seat belts. According to Eby, Bingham, Vivoda, & Rangunathan. (2011), when George Cayley firstly invented the seat belt to secure a person to a fixed object in the 1800s, the application was constrained to aircrafts to provide pilots with hooks and other attachments. In the 1930s, a U.S. physicians group saw the potential application of seat belts to automobiles, and Edward J. Claghorn received the first U.S. patent for automobile seat belts on February 10, 1885 in New York. The initial design of automobile seat belts had some serious weaknesses, however, as the modern three-point belt was designed, it became very effective for ensuring driver and passenger

safety (Eby et al., 2011). The safety belt used presently is estimated to reduce the probability of fatality by 40-45% and injury by 80%, depending on the crash type and vehicle type (NHTSA, 2001). In fact, the seat belt has prevented 168,524 fatalities in the period of 1960 to 2002 and saved 13,250 lives in 2008 alone in United States (NHTSA, 2008). It is also estimated that more than \$7 million was saved by translating injury reductions to medical care in 1996 (Williams, Reinfurt, & Wells, 1996). However, the usage of safety belt is not common worldwide. There are many factors that affect safety belt use, such as vehicle type, age, gender, population density, seating position, race, vehicle purpose, law type, time of day, income and education (Porter, 2011).

Several studies have been conducted to explore the behavior of safety belt use. Wilson (1990) found that drivers who report wearing safety belts “all the time” were lower sensation-seekers, less impulsive, and accumulated fewer traffic violations than non-users and “part-time” users. Those who were more likely not to wear safety belts were younger males and less education. The Committee for the Safety Belt Technology Study (CSBTS, 2004) also demonstrated that risky driving behaviors tended to co-occur among people who did not use safety belts; in other words, those not using safety belts were more prone to cell phone use, driver under the influence of alcohol, speed, commit more driving errors, accumulate more traffic violation, and be involved in fatal crashes.

Similar to the use of safety belts, only a small portion of motorcyclists wear helmets while riding motorcycles. Cited obstacles to using helmets include discomfort (“the helmet limits my visibility and hearing), underestimation of danger (“I don’t need

a helmet since I only ride short distances’), and risky behavior (“I am a risk-taking person”) (Papadakaki et.al, 2013).

2.2.2 Drowsiness

Beirness, Simpson, & Desmond (2005) defined drowsiness or sleepiness as an urge to fall sleep as the result of a biological need, and a physiological state of the body that is irresistible due to the lack of sleep. It was suggested that sleepiness was the second most frequent reason for both single and multiple motor vehicle crashes, where drinking and driving was the most frequent cause (Dingus, Hardee, & Wierwille, 1987). According to Akerstedt and Haraldsson (2001), sleep-related crashes are often found more severe and fatal. Actually, a survey study found that a majority of respondents (58.6%) admitted driving while tired or drowsy, 14.5% admitted having fallen asleep while driving over the past year, and nearly 2% were involved in crashes due to fatigue or drowsy driving in Ontario (Vanlaar, Simpson, Mayhew, & Robertson, 2008). It was also reported that 2.6% of the drivers who involved in fatal crashes were drowsy, ill, fatigued, asleep, or blackout in 2011 (FARS, 2011). Therefore, the threat of drowsy driving is very serious to traffic safety.

The risk of drowsiness has been explored by Shinar (1978). He argued that when people are drowsy, their capacity to process information is limited, not in the amount of information to see and to attend, but in the rate at which people process the information. The total amount of attentional capacity could be distributed among various driving and non-driving tasks in a drowsy driver. For example, a driver would be more attentive after a good night’s sleep; on the reverse side, lack of sleep will decrease the driver’s

attentional capacity, slow down reaction time, reduce awareness, and impair judgment. This helps explain why crashes are often more severe under drowsy driving conditions.

In addition, Romer (2003) found that those who were involved in drowsy driving also had tendencies towards sensation-seeking, impulsive decision-making, and low parental supervision.

2.2.3 Cell phone use

Up to June 2012, over 327 million cell phone users were reported in the U.S. (U.S. Wireless Quick Facts, 2012). Since the cell phone has become an essential tool used at work, driving while using a cell phone has become a growing traffic safety concern. A National Occupant Protection Use Survey (NOPUS) showed that about 6% of the drivers using a cell phone while behind the wheel were observed in 2005 (Glassbrenner, 2005), and two widely cited studies suggested that cell phone use increased crash risk by four times (Kenneth, Fang, & Wang, 2007). Although people may assume using hand-free phones are safer, Ishigami and Klein (2009) demonstrated that driving performance while using a hands-free phone was rarely found to be better than a handheld phone, and any type of cellphone use has negative impacts on driving. In fact, researchers found that drivers' reaction time was increased by comparable cognitive demands such as hand-free phone conversations (Engström, Aust, & Viström, 2010), and the allocation of visual attention (Reimer, Mehler, Wang, & Coughlin, 2012) and speed control (Reimer, Mehler, Coughlin, & Dusek 2011) were impaired when driving while using a cell phone. When analyzing the differences between cell phone-using drivers and non-users in Maryland, Kenneth et al. (2007) suggested that man

perspectives including personality, attitude, driving behaviors and lifestyle impacted drivers' driving.

Similar to drowsy driving, cell phone use while driving is a sign of distraction and could be explained by Shinar's concept of attention allocation (1978), which argued that the total amount of attentional capacity can be distributed among various driving and non-driving tasks. According to Shinar, people allocate their total attentional capacity to different tasks at the same time, but they rarely distribute the attention appropriately. According to Blumenthal (1968), performance level varies with time, and when insufficient attention is allocated to an increased demand, a crash may occur. Specifically, Shinar (1978) attributed around 45% of all the crashes to the insufficient attention distributed on the road.

2.2.4 Driving while intoxicated/driving under influence (DWI/DUI)

Alcohol-impaired driving is categorized as driving while intoxicated or driving under the influence (DWI/DUI) and refers to driving after having too much to drink. Unfortunately, even moderate alcohol consumption might impair driving performance, and the impending harm depends on the magnitude and severity of each situation (Chou et al., 2006). In fact, in 2011 30% of all traffic fatalities were related to alcohol-impaired driving with at least one driver or motorcycle rider blowing a BAC of .08 g/dL or higher, resulting in 9,001 deaths (NHTSA, 2011). In a study related to such behavior, Gibbons, Lane, Gerrard, Pomery, & Lautrup. (2002) found that one's perceptions of the dangers and crash possibility of drinking and driving had negative correlations with driving after drinking; for example, some drivers thought "driving after drinking was not dangerous

and the chance of being involved in a crash after drinking was small.” He suggested that individuals may also underestimate the risk of drinking and driving, and the individuals believe that it is acceptable and commonplace when driving a short distance. McCarthy, Pedersen, & Leuty (2005) also conducted a study in Missouri and found that an individual who had a crash experience while DUI was more lenient towards drinking and driving. In addition, spatial-temporal research conducted in Hong Kong indicated that the pattern of drinking and driving was related to the residential area, and drivers in rural areas tended to consume more alcohol than those in urban areas, regardless of the time of day (Li, Sze, & Wong, 2013).

Understanding drinking and driving attitudes and behaviors also helps to identify potential DUI offenders, as well as to develop prevention and intervention solutions. Specifically, Behaviors & Attitudes Drinking & Driving Scale (BADDs) is a recently developed scale and an effective tool, which focuses on the attitudes, behaviors, and intervention effectiveness related to impaired driving (www.thebadds.com). The BADDs is an evidence-based pre and posttest psychological questionnaire which can be completed within 10 minutes and contains four main scales including rationalizations for drinking and driving, likelihood of drinking and driving, drinking and driving behaviors, and riding behaviors with a drinking driver (Jewell, Hupp, & Segrist, 2008). BADDs has been widely used to evaluate drivers’ risky driving behaviors and provided assessment programs as interventions.

2.2.5 Aggressive driving

Aggressive driving is a prominent type of risky driving behavior that will be discussed in detail later in this chapter, along with its definition and examples.

2.2.6 Other factors

Other factors considered as risky driving behavior include: 1) thrill and adventure- seeking (Zuckerman, 2000); 2) driver's five personality traits, perception and cognition, and the social psychology of driving (Ulleberg & Rundmo, 2003); 3) driver's emotional state (e.g., stress and arousal) (Groeger & Rothengatter, 1998); 4) driving skills, speed, and distance perception ((VinjeÅ , 1981); 5) influence of peer passengers and lifestyle, such as watching movies in the car (Gregersen & Bjurulf, 1996); 6) unlicensed drivers (Hanna, 2013) and suspension offenders driving during periods of disqualification (Siskind, 1996). However, these factors will not delve into the details in this thesis, and a detailed study of aggressive driving are discussed in the next section.

2.3 Aggressive Driving behavior

Aggressive driving is highly prevalent among risky driving behaviors and very common in current society. In a survey conducted by NHTSA in 2002, nearly half (40%) of drivers admitted that they "sometimes" have entered an intersection just as the light turned from yellow to red, and 11% reported doing so "often." Moreover, one out of ten (10%) admitted "sometimes" cutting in front of another driver, and 2% reported doing so "often." In the same survey, one-third (34%) reported feeling threatened by other drivers a few times in a month (NHTSA, 2004). As a report from the American Automobile Association Foundation for Traffic Safety (2009) showed aggressive driving

leading to 212,427 deaths from 2003 to 2007, aggressive driving has become a growing problem in the U.S.

Buss (1961, p.1) defined aggressive behavior as “a response that delivers noxious stimuli another organism,” and hostility or hostile aggression can be defined as the action of aggressive behavior aims to harm the target by an emotional response, when an individual is anger (Buss & Durkee, 1957). In terms of driving, the NHTSA (2000, p.1) defined aggressive driving behavior as “a more ‘intentional’ and ‘hostile’ motor vehicle operational behavior that endangers road users or property, as compared to other risky driving behaviors.” From both definitions, it can be seen that aggression is emotion-related and often refers to “driving anger” or “road rage.”

According to the NHTSA (2000), some behaviors typically associated with aggressive driving include: exceeding the posted speed limit, failure to obey traffic control devices (stop signs, yield signs, traffic signals, railroad grade cross signals, etc.), improperly signaling lane changes, erratic or unsafe lane changes, and following too closely. Moreover, law enforcement agencies also have included RLR in their definition, since the NHTSA suggested RLR was one of the most dangerous forms of aggressive driving. Dula and Geller (2003) have summarized the examples of driver aggression from 19 studies into behavioral categories that include driving 10 mph or more over the speed limit, running stop signs and signals, failing to yield right-of-way, horn-honking, tailgating, hand gesturing, yelling, and feeling easily irritated and provoked by other drivers, can be considered aggressive driving behaviors. The certain behaviors addressed in this thesis are discussed in the following subsections.

2.3.1 Driving with aggression (DWA)

In 2011, 6.0% of the drivers involved in fatal crashes were driving in a reckless, erratic, careless, or negligent manner in the U.S. (FARS, 2011). To address this problem, three major classes of aggressive behavior were examined based on the example proposed by Dula and Geller (2003), as shown in the Table 2-2.

Table 2-2: Major Classes of Aggressive Behavior

Class	Example
Intentional acts of bodily and /or psychological aggression toward other drivers, passengers, and/or pedestrians	Physical, gestural, and/or verbal in nature
Negative emotions felt while driving	Frustration, anger and rage, sadness, frustration, dejection, jealousy
Risk-taking behaviors	Dangerous behaviors performed without intent to harm self or others

The action of any behaviors stated in the above table while driving were defined as “driving with aggression (DWA)” in this study. In words, honking, tailgating, gesturing, and shouting or being angry at other drivers at the wheel are the examples of DWA.

To be specific, aggression comes from various sources including:

- 1) Road conditions: crowding, congestion, delays (Lajunen, Parker, & Summala, 1999; Shinar & Compton, 2004; Jovanovic, Lipovac, Stanojević, & Stanojević, 2010; Liu & Lee, 2005)
- 2) Driver’s negative emotions: anger, annoyance, anxious, highly irritable, and frustration (Millar, 2007; Nesbit, Judith Conger, & Anthony Conger, 2007;

- Nesbit & Conger, 2012; Berdoulat, Vavassori, & Sastre, 2013; Lajunen & Parker, 2001; Wickens, Mann, Stoduto, Anca, & Smart, 2011)
- 3) Driver's mood status: time pressure and urgency (Lajunen & Parker, 2001; Shinar & Compton, 2004)
 - 4) Driver's personality traits: impatience, completive, impulsiveness, sensation-seeking, risk-taking, aggressive disposition and hostility (Jovanovic et al., 2010; Dahlen et al., 2012; Constantinou, Panayiotou, Konstantinou, & Loutsiou-Ladd Anthi, 2011; Berdoulat et al., 2013; Benfield, Szlemko, & Bell, 2007; Miles & Johnson, 2003; Chliaoutakis et al., 2002)
 - 5) Motivation for driving: joyriding and provoking of passengers (Papadakaki et al., 2013)
 - 6) Driver's information: age and gender, driving experience, dysfunctional attitudes towards safety (Liu & Lee, 2005), and beliefs (public self-consciousness) (Lajunen & Parker, 2001; Wickens et al., 2011)
 - 7) Presence or absence of passengers in the car, and type of perceived status of the vehicle (Shinar & Compton, 2004)

Furthermore, Efrat and Shoham (2013) found that drivers who value material possessions (materialism) were more likely to be involved in aggressive driving. To be precise, if happiness achieved through acquiring or possessing material goods is not fulfilled, negative emotions such as frustration and aggression will be triggered, which will eventually result in aggressive behaviors (Efrat & Shoham, 2013).

2.3.2 Speeding

Speeding refers to individual driving with an exceeding speed over the limit on the road. Many researchers have indicated that speeding is a very dangerous driving behavior and should be considered one of the most important contributors to specific kinds of crashes (e.g., right of way violations, active shunts or reversing, and loss of control) (West & Hall, 1997). According to statistic compiled by FARS in 2011, 20.8% of drivers involved in fatal crashes during that year were driving too fast in excess of posted limit for conditions in the U.S. In Iowa specifically, 12.5% of the drivers who involved in fatal crashes were driving too fast when the crashes occurred in Iowa (FARS, 2011). In fact, Baum, Wells, & Lund (1991) found that when the speed limit increased to 65 mph on rural interstates, the number of fatalities increased by 19%, after making the adjustments for the VMT and passenger vehicle occupancy rates.

McKenna and Horswill (2006) explored the reasons for people driving with an excessive speed and proposed the idea of a *low probability of negative outcome*. To be specific, drivers may assume that their risk of being involved in crashes or caught by the police for speeding is small. The reasons for speeding included in this study, such as running late, not paying attention to the speed, keeping up with the flow of traffic, and enjoying the thrill of driving fast, will be described in the next chapter. McKenna and Horswill (2006) also demonstrated that variables, such as mood, journey time, passengers, thrill, legal constraints, and economics, had significant influences on speeding. In particular, Clarke et al. (2002) found that excessive speeding involved mostly young drivers.

2.3.3 Red-light running (RLR)

Red-light running (RLR) is one of the most risky of all aggressive driving behaviors and occurs frequently in urban areas. Based on Manual on Uniform Traffic Control Devices (MUTCD, 2009), RLR was defined in two ways. The first one was under a “permissive yellow” rule that a driver could legally enter the intersection during the entire yellow interval. In this case, RLR refers to a violation when a driver entered an intersection after the onset of a red light. The other rule was “restrictive yellow” that a driver could neither enter nor be in the intersection on a red light. Under this situation, RLR refers to a violation when a driver had not cleared intersection after the onset of a red light. RLR has become a serious threat, so much so that about 40% of the 5,811,000 crashes occurring in the U.S. in 2008 were estimated to be intersection-related (FARS, 2008), and 4.2% of the drivers involved in the fatal crashes in 2011 failed to obey traffic signs, signals, or an officer while driving, with a higher percentage of 5.7% found in state of Iowa (FARS, 2011). Retting, Williams, Preusser, & Weinstein (1995) and Retting, Ulmer, & Williams (1999) also suggested that RLR was a main cause accounting for 22% of urban crashes in 1995 and 3% of the total fatal crashes from 1992 to 1996, during which period fatalities related to RLR increased by around 15%.

Researchers have conducted many studies to investigate RLR behavior. Retting and Williams (1996) found that the red-light runners were always below 30 years old had worse driving records and driving smaller, older vehicles than non-violators. Furthermore, Retting et al. (1999) indicated that red-light runners were more likely to be young males with invalid driver’s licenses and had alcohol consumptions; in particular,

those who were deviant and driving after drinking were more likely to run red-light at night. In a later study, Porter and England (2000) argued that RLR rates were related to the size of the intersection, traffic volume, time of day, safety belt use, and ethnicity. Also, Porter and Berry (2001) demonstrated that violators were more likely to drive alone and in a hurry. They also found that a driver's characteristics, attitudes, and the presence of passengers were important predictors of RLR behavior. Recently, Elmitiny, Yan, Radwan, Russo, & Nashar (2010) also showed that moving speed, vehicle's distance from the intersection, and positions in the traffic flow were significantly associated with RLR. In addition, Palat and Delhomme (2012) illustrated that a driver's motivations for RLR could be predicted by the Theory of Planned Behavior (TPB) factors of attitude and the descriptive norm, which will be described in the next section.

2.4 Risk Taking Theory

To explore risky behaviors and alleviate the problem of drivers engaging in risky behaviors, several theories such as Risk Homeostasis Theory (RHT), Theory of Reasoned Action (TRA), Theory of Planned Behavior (TPB), and other variations have been developed and are presented in this section.

2.4.1 Risk homeostasis theory (RHT)

Risk homeostasis theory is the best-known motivation model which accounts for a host of overall driver behavior (Shinar, 2007). The central processor of this idea is known as target risk, which refers to a certain level of risk to peoples' particular safety

or anything else they value that people would accept in order to gain benefits from a particular activity (Wilde, 1998; 2002). In fact, target risk can be either relatively stable and long lasting related to cultural norms and values (e.g., economy, peer-group attitudes, level of education, age group, and gender), or shorter-term and occur within an individual (e.g. specific purpose of trip or urgency to arrive on time, mood, fatigue) (Wilde, 1994). According to Wilde (1998; 2002), people tend to evaluate the risk they are taking presently and compare to the amount of risk they would like to accept. To be more exact, if the risk is lower than acceptable, drivers will change behavior to be more dangerous; if risk is evaluated as higher than acceptable, drivers will compensate risk with more cautious behavior.

Risk perception involved in this theory refers to a subjective norm on the risk of potential hazards in driving behaviors (Deery, 1999). To clarify, the target level of accepting risk is different among individuals; some drivers (especially young drivers) are more prone to take risks than others, and sensation-seeking (SS), such as thrill and adventure-seeking, based on their motivations and attitudes. They might set a higher level of risk to fulfill their driving needs and increase competence if no negative consequence, such as injury or penalty, would occur (Horvath & Zuckerman, 1992). Moreover, their level of target risk and perceptual skills are constant during a certain phase in life (Shinar, 2007).

Apart from the acceptance of target risk and risk perception, risk taking behavior is also associated with driving skills and abilities. In particular, inexperienced drivers are a population that is less skillful at predicting and detecting hazards. Inexperienced

drivers also underestimate risks and fail to link risks to the occurrence of crashes (Groeger et al., 1989). This may be because young drivers underestimate the risk of a crash in a variety of hazardous situations and overestimate their own driving skills (Deery, 1996).

Other reasons for taking risks while driving include personality (Dahlen et al., 2005), alcohol use, friends' support for drinking, susceptibility to peer pressure, and tolerance of deviance (Shope, et al., 2003), worry and concern (Rundmo & Iversen, 2004), and memory of risk-related, emotionally arousing driving events (Maycock et al., 1996).

2.4.2 Theory of reasoned action (TRA)

In 1975, Fishbein & Ajzen proposed a model of Theory of Reasoned Action (TRA) to determine human behavior, which addresses the impacts of cognitive components of attitudes, social norms, and behavioral intentions. The theory demonstrates that the intention of engaging in certain behaviors, which may further lead to the enactment of the behavior, can be predicted from an individual's attitudes towards that behavior and the personal norms representing an individual's perception of others' views concerning that behavior. In TRA, the intention to display a particular behavior is predicted by the personal factor of attitude towards the behavior and a social factor of a subjective norm (Fishbein & Ajzen, 1975; Taylor & Todd, 1995), as shown in Figure 2.1. Each individual component of TRA is discussed in the following subsections.

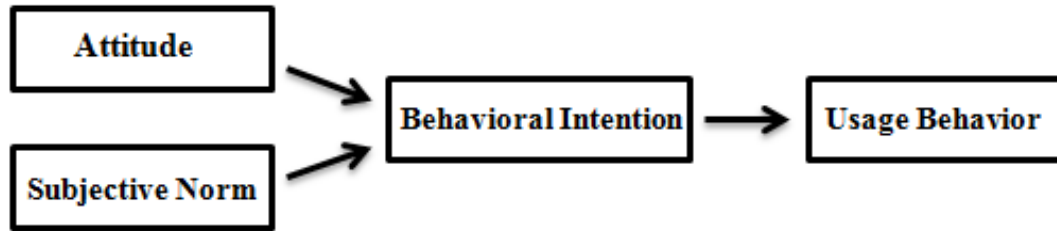

Figure 2.1 Schematic representation of the TRA (adopted from Fishbein & Ajzen, 1975)

2.4.2.1 Attitude

According to Fishbein and Ajzen (1975), attitude which determines behavioral intention directly and the actual behavior indirectly is classified into two categories: attitude towards the object and attitude towards the specific behavior. Based on the authors' definitions, attitude is individual's feelings or thoughts that either favor or against an object, an attribute, or a belief. And an attitude towards the specific behavior refers to individual's beliefs to act out a certain behavior. Ajzen and Fishbein (2000) also gave a more recent definition of attitude as an individual's feeling towards a certain behavior or towards the action of this behavior. An example of one's attitude towards speeding might be perception that excessive speeding is a serious threat to traffic safety.

2.4.2.2 Subjective norm

A subjective norm refers to an individual's expected perception from the group of people who have some sort of influence on the individual (Fishbein & Ajzen, 1975). It is comprised of the impacts or pressures from the social environment on the individual, which increases with the display of the certain behavior (either reward or punishment) (Fishbein & Ajzen, 1975). In other words, a subjective norm encompasses the

individual's beliefs that weighted by the importance of others' opinions of one attribute. An example of one's subjective norm might be a belief that wearing a safety belt while driving is good, because parents or friends suggest it.

2.4.2.3 Behavioral intention

According to Fishbein and Ajzen (1975), behavioral intention is a result of an individual's attitude and subjective norm toward that behavior, which is used to predict actual behavior. The two core components of the model, attitudes and subjective norms, with their own weights, are used to predict the actual behavior, as shown in the following algebraic expression (Fishbein 1967):

$$B \sim BI = [A - act]w_0 + [NB(Mc)]w_1$$

where: B = overt behavior; BI = behavioral intention; A-act = attitude toward performing a given behavior in a given situation; NB = normative beliefs; MC = motivation to comply with the norms; w_0/w_1 = empirically determined weights.

Theoretically, w_0 and w_1 of the attitude and normative components should be estimated for each subject separately. Nevertheless, when individual weights cannot be obtained because of the methodology limitations, a multiple regression analysis is used in the estimation, where A-act and NB (MC) are the predictor variables, and BI is the criterion (Ajzen & Fishbein, 1970).

TRA can be expressed in its simplest form as the following equation (Hale & Greene, 2003):

$$BI = (AB)W_1 + (SN)W_2$$

where: *BI* = behavioral intention; *AB* = one's attitude toward performing the behavior; *W* = empirically derived weights; *SN* = one's subjective norm related to performing the behavior.

2.4.3 Theory of planned behavior (TPB)

The Theory of Planned Behavior (TPB) is an extended and revised model for TRA designed to compensate for the limitations of an individual's incomplete volitional control (Ajzen, 1991). Specifically, a third primary predictor variable known as perceived behavioral control (PBC), which refers to the perception of internal or external resource restricted to perform this behavior, is included in the extended model. The addition of PBC considers unsatisfactory experience, when people have intended to implement a behavior, but eventually failed due to the lack of control or confidence in this behavior (Miller, 2005). In TPB, individual's intentions are predicted by their attitudes, their subjective norms, as well as perceived behavioral control (Ajzen, 1991). Ajzen's model (1991) of TPB is presented in Figure 2.2.

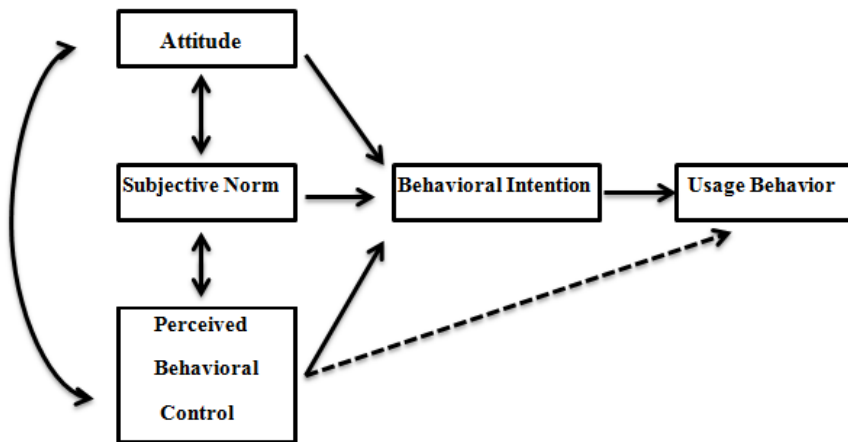

Figure 2.2 Schematic representation of Ajzan's TPB (adopted from Ajzan, 1991)

Besides RHT, TRA, and TRB, there are some other less commonly used theories, which are discussed in the following section.

2.4.4 Other theories

Some other theories have been developed based on variations and modifications of TRA and TPB. For instance, the Decomposed Theory of Planned Behavior, which is a variation of TPB, merges the three models of TRA, TPB and Technology Acceptance Model (TAM) (Taylor & Todd, 1995). Furthermore, Reinforcement Sensitivity Theory (RST) is another theory used to provide a conceptual basis in driving behaviors analysis (Brady, 2006; Constantinou et al., 2011); it involves motivational components such as sensation seeking and impulsivity (Gray, 1987).

Among all the mentioned theories, the TRA which involves explicit factors of attitudes, subjective norms, and behavioral intentions, matches with the data of this study most closely. Therefore, TRA is selected to provide the basis of this analysis. In fact, the

TRA and its extension of TPB are widely used in analyzing the risky driving behaviors. Four studies that applied these theories are presented in the next section.

2.5 Theory Applications

Jonah and Dawson (1982) conducted a study to estimate seat belt use in the Province of Ontario, a region where the use of seat belts is compulsory. Two samples that were randomly drawn from telephone directories consisted of 445 drivers in the first sample and 438 drivers in the second one. The drivers were interviewed by telephone and asked about their attitudes towards seat belt use and seat belt legislation, the social influence of others, and reported belt usage. Drivers' demographic status was also included. Their answers were reported in seven-point Likert type scales on 11 belief statements concerning the effectiveness, comfort, and convenience of seat belts. The TRA was applied to examine attitudinal and normative factors which predicted the self-reported seat belt use in the study area. The results demonstrated that attitudinal and normative factors made significant and unique contributions to the prediction of reported seat belt use. Specifically, the attitude toward the seat belt and its legislation, perceived belt use and social pressure from the community predicted the reported use of seat belts. The model represented a good fit and it is an excellent application of Fishbein's theory on traffic safety.

Letirand and Delhomme (2005) studied the speeding behaviors of exceeding and not observing the speed limit using the TRA. In this study, the administered questionnaire consisted of three parts designed to evaluate the situation perception (straight road with a speed limit of 90 km/h) and self-reported speeding behavior of the

238 young male drivers aged from 18 to 25 years. The results indicated that the participants' evaluations of the two options positively impacted their self-reported speeding behavior and intentions. This study is another great example of the TRA's application of the assessment of drivers' behavior.

In addition to the TRA, the modified model of the TPB is also widely used in predicting driving behavior such as the speeding behavior in a rural area. Forward (2010) explored the impacts of attitudes, subjective norms, perceived behavioral control and descriptive norms in speeding motivation through an extension of the TPB. 1798 drivers that were randomly selected from the general public in Sweden were asked to complete a questionnaire containing various items which measured speeding intention, behavioral beliefs, subjective norms, and perceived behavioral control in a rural area. The key findings of the study showed that positive beliefs, descriptive norms, and females' driving experience and age were significant predictors of speeding intention on rural roads. In addition, the differences between males' and females' intentions were both predicted very well in this model. Therefore, the study provides directions for developing a comprehensive statistical model using the theory.

Most recently, Efrat and Shoham (2013) analyzed aggressive driving based on the TPB to explore the personality traits of aggressive drivers. A questionnaire-based survey measuring materialism (rooted in definitions of envy, possessiveness, and non-generosity), aggressive driving behavior, and the TPB (rooted in concepts of initiatory and retaliatory aggression) was dissipated in twelve of the large industries in northern Israel, and yielded 220 responses. A materialism-mediating model was constructed to

estimate aggressive driving intentions, which were predicted by attitudes, subjective norms, and perceived behavioral control. The results showed that materialism played an important role in an individual's aggressive driving behavior. The model also verified the application of the TPB in predicting intentions. In summary, this study offers a vital frame to establish an analytical model on predicting aggressive driving behavior. Moreover, SEM technique was involved in analyzing the model. This methodology is very significant and will be discussed in detail in the following chapter.

2.6 Review of Literature

After an overview of the definitions and examples of risky and aggressive driving behaviors, as well as various risk-taking theories and their applications, Table 2-3 provides a list of the reviews of the national and international studies on the issue of risky and aggressive driving behavior.

Table 2-3: Summary of Review of Literature in Different Technology Adoption

Study and Location	Objective	Data and Methods	Results
Beck, et al. (2007) Maryland, US	Investigate risky driving behaviors and compare cell phone using drivers with non-use drivers while driving	Annual telephone surveys (April/May in 2003, 2004, 2005, 2006) using logistical regression analyses	Drivers who use a cell phone while driving tended to drive more riskily and be involved in crashes than non-cell phone using drivers

Table 2-3 Continued: Summary of Review of Literature in Different Technology

Study and Location	Objective	Data and Methods	Results
Chang et al. (2011) Taiwan, China	Explore the crash risk and driving behaviors of ALLR (Administrative Lifetime Driver's License Revocation) drivers	Self-report questionnaire (September 2003) using logistic regression model	The crash risk of offenders was significantly correlated with their personal characteristics, penalty status, annual distance driven, and needs for driving
Hanna et al. (2013) Montana, US	Investigate health risk behaviors of young unlicensed drivers, comparing licensed driving and non-driving peers	Self-reported car driving and license practice using multinomial logistic regression	Young, unlicensed drivers had a higher possibility to take health risks such as drunk drinking, compared to licensed drivers
Harbeck and Glendon (2013) Australia	Estimate the involvement in 10 risky driving behaviors: speeding, alcohol use, racing, cell phone use, tailgating, unsafe overtaking, fatigue, and not wearing a seat belt	Questionnaire completed by psychology students using SEM ¹ analyses	RST variables, negative reactivity, reward responsiveness, and fun-seeking resulted in differences of perceived risk among young drivers
Hutchens et al. (2008) Pennsylvania, US	Explore risk factors for teenagers and young adult drivers involved in crashes	Telephone survey using multivariate logistic regression	Only driving alone while drowsy was associated with having been in a crash
Iversen (2004) Norway	Determine the role of attitudes towards traffic safety issues for future risky behavior in traffic	Two mail questionnaire surveys (autumn 2000/2001) using PCA ² and LISREL ³ analysis	Engagement in traffic crashes in the last year was a predictor of risk taking in driving behaviors

Table 2-3 Continued: Summary of Review of Literature in Different Technology

Study and Location	Objective	Data and Methods	Results
Machin and Kim (2008) Australia	Investigate the impacts of personality factors and risk perceptions on driving behavior among young, inexperienced drivers	Online questionnaire using SEM	Excitement-seeking, altruism, aversion to risk taking, and likelihood of having an accident were the main causes of speeding behavior among young drivers
Mirman et al. (2012) Pennsylvania, US	Explore the effect of individual differences such as sensation seeking, risk perceptions, and parenting factors on involvement in adolescents' risky driving behavior	A cross-sectional web-based survey using regression analysis	Stronger risk perceptions (RPs) and parents were monitors and rule setters
Møller and Gregersen, (2008) Denmark	Examine the relation between risky driving behavior, the psychosocial function of driving, leisure time activities, car-oriented peer group interaction, and educational attainment	A mailed questionnaire survey (combination of 1999, 2002 & 2004 studies) using multiple linear regression analysis	Psychosocial factors of driving, low structure/high impulsivity leisure time activities, interaction such as body building and partying with friends were reported as having a positive, significant impact on risk-taking behavior

Table 2-3 Continued: Summary of Review of Literature in Different Technology

Study and Location	Objective	Data and Methods	Results
Musselwhite (2006) London, UK	Investigate the relation between motivations and attitudes towards risk and risk taking behavior in car driving	Four groups of comprehensive samples using hierarchical cluster analysis	Drivers took risks when in a hurry, reacting to stress, and feeling safe
Papadakaki et al. (2008) Greece	Explore how sleep-related factors and various lifestyle patterns are related to road risk	Personal interviews and self-administrated questionnaire using LISREL, PCA, and multiple linear regression analysis	Gender, daytime sleepiness, sleep quality, and the lifestyle of “amusement” had significant effects on drowsy driving
Scope et al. (2003) Michigan, US	Test the effects on risk driving behavior from adolescent alcohol use, friends’ support, peer pressure, and tolerance of deviance over time	Self-administered and school-based questionnaires using regression models	Four predictors had significant effects in predicting serious offenses, alcohol-related offenses, and alcohol-related crashes
Tefft (2012) United States	Estimate the proportion of crashes with drowsy driver engagements in passenger vehicles	A representative sample of crashes (1999-2008) using univariate Poisson regression analysis	Crash level: 7.0% of all crashes, 13.1% of non-fatal crashes, and 16.5% of fatal crashes involved drowsy drivers Driver level: 4.1% of all crashes, 8.4% non-fatal crashes, and 11.6% of fatal crashes that drivers were drowsy

Table 2-3 Continued: Summary of Review of Literature in Different Technology

Study and Location	Objective	Data and Methods	Results
Zhao et al. (2012) Boston, US	Measurements of actual highway driving performance	Driving Behavior Questionnaire (DBQ) using regression analysis	Higher frequency of cell phone use while driving increased the overall risk of crash involvement

Note: [1] Structural Equation Modeling; [2] Principal Component Analysis; [3] Linear Structural Relation

2.7 Summary

Motor vehicle crashes are the leading cause of deaths in the U.S., and human errors and inappropriate driving behaviors account for 85% to 95% of these crashes. These risky driving behaviors, including not using seatbelts, drowsy driving, DWI/DUI, cell phone use, and aggressive driving, are serious threats to traffic safety and public health. Risk behaviors also tend to occur together; for instance, red-light runners may also be involved in other risky driving behaviors such as speeding, more often.

Aggressive driving, one very risky driving behavior including DWA, RLR and speeding, is defined as a more intentional and hostile driving behavior that threatens road users and property. Specifically, aggression develops from various sources, such as road conditions and driver's mood status. Three major classes of aggression includes intentional bodily acts (like gestures), negative emotions (like frustration), and risk-taking perceptions. Different theories that explain the reasons of individual taking risks include RHT, TRA, and TPB, as well as several variations on these theories. In particular, TRA and TPB, both of which illustrate the relation among attitudes,

subjective norms, perceived behavior control, and behavioral intentions, have been widely used in analyzing various risky driving behaviors. Among the theories, the TRA matches with the scenario of this study best and will, therefore, be used as the basis of this analysis.

Lastly, the review of national and international literature examined the impact of various risky and aggressive driving behaviors and provided research directions. Recall from Chapter 1, one of the limitations from past studies was that they have focused on only one specific behavior. In light of this limitation, this this research aims to investigate the interactions and relationships of several behaviors. Past studies also have emphasized the impacts from psychological factors, and this study will examine more factors from an engineering perspective.

CHAPTER 3

METHODS

3.1 Overview

The data used in this study was adopted from a public opinion survey questionnaire designed by the University of Northern Iowa's Center for Social and Behavioral Research in 2011. The survey was used to collect information for the policy makers to produce traffic safety policies, strategies, and practices that would ultimately improve the overall traffic safety culture across Iowa.

This chapter first discusses the questionnaire survey briefly and provides the general results related to aggressive driving behaviors. Secondly, in order to make stronger indicators, the raw responses from the questionnaire were recoded and several indices were created. The process of measuring data is also shown. Finally, the analysis plan of Structural Equation Modeling (SEM) that used to examine aggressive driving behavior of adult Iowans is illustrated. The specification and estimation the SEM parameters are introduced, followed by the criterion of model evaluation and criticism. SEM applications on transportation safety are presented lastly.

3.2 Sampling Procedures

In April 2011, the Center for Social & Behavioral Research at the University of Northern Iowa designed a cell phone and landline questionnaire survey to assess public opinions on traffic safety and examine driving experience with adult Iowans. The survey contained 50 questions on various traffic safety topics that representing diverse

disciplines of law enforcement, public policy, safety advocacy, public health, education, social psychology, and engineering (Albrecht, Li, & Gkritza, 2013). In addition, the demographic-and socioeconomic-status of participants was also involved.

All the participants were adult Iowans over the age of 18 and randomly selected from various cities statewide. A total of 1088 final-completed interviews were collected, with 684 of which from landline interviews and 404 from cell phone. The complete survey questionnaire is presented in Appendix A: Public Survey Questionnaire on Traffic Safety Culture in Iowa.

3.2.1 Iowa telephone survey

According to the Albrecht et al. (2013), the 2011 public opinion survey covered a comprehensive review of the safety culture issues and assisted to set a total of 11 goals to identify the potential traffic safety concerns raised in Iowa: 1). Improve Emergency Medical Service (EMS) Response; 2). Toughen Law Enforcement and Prosecution; 3). Increase Safety Belt Use; 4). Reduce Speeding-Related Crashes; 5). Reduce Alcohol-Related Crashes; 6). Improve commercial vehicle safety; 7). Improve Motorcycle Safety; 8). Improve Young Driver Education; 9). Improve Older Driver Safety; 10). Strength Teenage Licensing Process; and 11). Reduce Distracted Driving.

3.2.2 Survey results

8,165 adult Iowans randomly selected from various cities statewide were contacted (4,316 through landlines and 3,849 through cells) and 1,088 completed

interviews (684 landlines and 404 cells) were finally yielded. The Response Rate (RR3) was 37% for the total sample (36% landline sample, 41% cell phone sample), and the Cooperation Rate (CR3) was 69% for the total sample (67% landline sample, 72% cell phone sample). The results of the 2011 survey classified by the identified 11 high-level goals are presented in Appendix Table A-1.

3.3 Data Measurements

As the original data used in this study is from questionnaire, some limitations such as measurement problems exist while handling the survey responses. An appropriate measurement of the original data that collects, captures, and manipulates the important items would address the reliability and validity of survey responses, and then produces meaningful information (French, 1996). Therefore, several techniques including recoding, creating indices, and dummy coding were used to measure the original data, based on the judgments as a statistician and an engineer in the following sections. The variables of Perception, Acceptance, Permissiveness, and Experience will be delineated in this thesis with capital letters, whereas the concepts of perception, acceptance, permissiveness, and experience will be distinguished with lower letter.

3.3.1 Data recoding

In a bit to make the explicit sense of variable's direction which implies a high or low inclination of certain behaviors, the questions corresponding to aggressive driving behaviors including speeding, RLR, and DWA selected from the questionnaire were recoded prior to model construction. The responses of respondents' perception of,

acceptance/permissiveness of, and experience with each behavior were recoded to provide directions for the responses. To be more precise, the responses were coded into an ascending order where higher scores indicated more aggressive inclinations. The descriptive statistics after recoding are presented in Table 3-1.

3.3.2 Created indices

In order to obtain better estimates of aggressive driving behaviors, several indices were created to strengthen the internal bonds of the each predictor. The index was adapted from the survey questions corresponding to perceptions and acceptance on speeding, RLR, and DWA, individually. For example, the original survey included three items under Q19 (“How acceptable to you personally think it is for a driver to...?”), and the three items of “drive 10 mph over the speed limit on a city street”, “drive 10 mph over the speed limit on a freeway”, and “drive 10 mph over the speed limit on a rural gravel road” were all reflected by the acceptance of speeding. To make a stronger predictor, the three items were collapsed and constituted an index named “acceptance of speeding.” Each item in the index was scored from 1 to 4, a total of scores from 3 to 12 were obtained after the summation. For consistency, the total scores were converted to the average of the responses by dividing the number of items, which was 3 in this case. Thus, the scores in the new index were in accordance with the scores in the survey, and the original survey response was removed reasonably. Similarly, questions corresponding to RLR and DWA were also adapted to new indices such as perception of speeding, acceptance of RLR, perception of RLR, and perception of DWA, separately, using the same approach.

However, as each event may occur independently from other events, two more steps were processed before applying the above measurements in order to make an appropriate prediction of data. First, inter-correlations for the items under each corresponding question were examined to establish evidence for construction and criterion validity of each item. Second, the internal consistency among the items was estimated to evaluate their reliabilities and associations that representing a specific behavior. Cronbach's (1954) alpha is a measure of the internal consistency of a series of items. Higher scores on Cronbach's alpha depend on the average magnitude of the correlations between items that make up an index and the number of items. The higher the average correlation and the more items being correlated, the higher the alpha value is. The Cronbach's α values of the predictors ranged from 0 to 1 are presented in Table 3-1, a value closer to 1 indicates a stronger reliability and association among the items under a predictor. As a general rule, alphas greater than 0.70 indicate high consistencies, however, alphas between 0.50 and 0.70 are also considerable. The inter-correlation matrix of the items under a predictor estimated by full information maximum likelihood (FIML) method is shown in Table 3-2.

Table 3-1: Descriptive Statistics After Recoding and the Reliability of the Indicators

Question	N	Mean	S.D.	Cronbach's α
Speeding				
Q19. How acceptable to you personally think it is for a driver to...? c. Drive 10 mph over the speed limit on a city street g. Drive 10 mph over the speed limit on a freeway l. Drive 10 mph over the speed limit on a rural gravel road [1: Never, 2: Seldom, 3: Sometimes, 4: Always]	c. 1086 g. 950 l. 945	c. 1.35 g. 2.16 l. 1.53	c. 0.71 g. 1.01 l. 0.86	0.6156
Q20. Please tell me how often you have seen other drivers in your area do the following... c. Speed through a yellow traffic light d. Drive 10 miles per hour over the speed limit on a major highway e. Drive 10 miles per hour over the speed limit on a city street n. Drive 10 mph over the speed limit on a rural gravel road [1: Never, 2: Once a month, 3: Few a month, 4: Few a week, 5: Everyday]	c. 944 d. 933 e. 946 n. 839	c. 3.62 d. 3.98 e. 3.38 n. 2.36	c. 1.21 d. 1.10 e. 1.32 n. 1.32	0.6981

Table 3-1 continued: Descriptive Statistics After Recoding and the Reliability of the Indicators

Question	N	Mean	S.D.	Cronbach's α
Q21. In the past 30 days, as a driver of a vehicle, have you ... Speeding?	e. 915	e. 1.13	e. 0.34	0.3438
	f. 915	f. 1.39	f. 0.49	
e. Been asked by a passenger to slow down or drive more carefully while driving	g. 915	g. 1.11	g. 0.32	
f. Driven 10 mph over the speed limit on a highway or interstate	h. 914	h. 1.47	h. 0.50	
g. Driven 10 mph over the speed limit on a city street	i. 909	i. 1.09	i. 0.29	
h. Felt pressure from other drivers to drive faster				
i. Driven 10 mph over the speed limit on a rural gravel road				
[1: Yes, 2: No]				
Red Light/Stop Sign Running (RLR)				
19. How acceptable do you personally think it is for a driver to:	e. 1088	e. 1.28	e. 0.64	0.4463
	j. 1087	j. 1.22	j. 0.57	
e. Drive through a light that just turned red, when they could have stopped easily?	k. 1088	k. 1.36	k. 0.75	
j. Drive through a stop sign if the way looks clear?				
k. Make a right turn at a red light without stopping?				
[1: Never, 2: Seldom, 3: Sometimes, 4: Always]				

Table 3-1 continued: Descriptive Statistics After Recoding and the Reliability of the Indicators

Question	N	Mean	S.D.	Cronbach's α
20. Please tell me how often you have seen other drivers in your area: f. Drive through red lights on purpose l. Drive through a stop sign m. Turn right at a red light without stopping [1: Never, 2: Once a month, 3: Few a month, 4: Few a week, 5: Everyday]	f. 1059 l. 1076 m. 1078	f. 2.32 l. 2.71 m. 2.79	f. 1.18 l. 1.20 m. 1.24	0.7547
Q21. In the past 30 days, as a driver of a vehicle, have you ... Lights/stop signs? j. Driven through a light that has just turned red, when you could have stopped safely k. Sped up to get through a yellow light before it changed l. Turned right at a red light without stopping m. Driven through a stop sign [1: Yes, 2: No]	j. 1042 k. 1041 l. 1042 m. 1044	j. 1.07 k. 1.51 l. 1.06 m. 1.09	j. 0.26 k. 0.50 l. 0.23 m. 0.28	0.2399
Driving with Aggression (DWA)				
20. Please tell me how often you have seen other drivers in your area: b. Honk at other drivers c. Speed through a yellow traffic light h. Tailgate other vehicles j. Become visibly angry at something another driver did [1: Never, 2: Once a month, 3: Few a month, 4: Few a week, 5: Everyday]	b. 1080 c. 1076 h. 1073 j. 1074	b. 2.75 c. 3.63 h. 3.52 j. 2.67	b. 1.19 c. 1.21 h. 1.30 j. 1.17	0.7559

Table 3-1 continued: Descriptive Statistics After Recoding and the Reliability of the Indicators

Question	N	Mean	S.D.	Cronbach's α
Q21. In the past 30 days, as a driver of a vehicle, have you ...?	t. 1042	t. 1.09	t. 0.29	0.1327
t. Tailgated another vehicle	u. 1043	u. 1.28	u. 0.45	
u. Became extremely angry at something another driver did	v. 1043	v. 1.20	v. 0.40	
v. Honked at other drivers	w. 1041	w. 1.35	w. 0.48	
w. Tried to avoid driving on a certain road because you felt it was dangerous				
[1: Yes, 2: No]				

Table 3-2: Inter-correlation Matrix of the Items Under Corresponding Questions

Speeding Acceptance	Q19 (c)	Q19 (g)	Q19 (l)	
Q19 (c)	1			
Q19 (g)	0.34	1		
Q19 (l)	0.35	0.38	1	
Speeding Perception	Q20 (c)	Q20 (d)	Q20 (e)	Q20 (n)
Q20 (c)	1			
Q20 (d)	0.47	1		
Q20 (e)	0.44	0.44	1	
Q20 (n)	0.23	0.34	0.30	1

Table 3-2 continued: Inter-correlation Matrix of the Items Under Corresponding Questions

Speeding Experience	Q21 (e)	Q21 (f)	Q21 (g)	Q21 (h)	Q21 (i)
Q21 (e)	1				
Q21 (f)	0.13	1			
Q21 (g)	0.08	0.28	1		
Q21 (h)	0.03	-0.00	0.01	1	
Q21 (i)	0.19	0.26	0.18	-0.02	1
RLR Acceptance	Q19 (e)	Q19 (j)	Q19 (k)		
Q19 (e)	1				
Q19 (j)	0.24	1			
Q19 (k)	0.14	0.28	1		
RLR Perception	Q20 (f)	Q20 (l)	Q20 (m)		
Q20 (f)	1				
Q20 (l)	0.52	1			
Q20 (m)	0.49	0.51	1		
RLR Experience	Q21 (j)	Q21 (k)	Q21 (l)	Q21 (m)	
Q21 (j)	1				
Q21 (k)	0.14	1			
Q21 (l)	0.13	0.05	1		
Q21 (m)	0.07	0.02	0.16	1	
DWA Perception	Q20 (b)	Q20 (c)	Q20 (h)	Q20 (j)	
Q20 (b)	1				
Q20 (c)	0.40	1			
Q20 (h)	0.37	0.51	1		
Q20 (j)	0.49	0.42	0.43	1	

Table 3-2 continued: Inter-correlation Matrix of the Items Under Corresponding Questions

DWA Experience	Q21 (t)	Q21 (u)	Q21 (v)	Q21 (w)
Q21 (t)	1			
Q21 (u)	0.05	1		
Q21 (v)	0.13	0.22	1	
Q21 (w)	0.04	-0.07	-0.07	1

The results demonstrated that the indices of acceptance of speeding (Cronbach's $\alpha=0.6156$), perception of speeding (Cronbach's $\alpha=0.6981$), acceptance of RLR (Cronbach's $\alpha=0.4463$), perception of RLR (Cronbach's $\alpha=0.7547$), and perception of DWA (Cronbach's $\alpha=0.7559$) had predictive validities and fine internal consistency, with the Cronbach's α coefficients ranged from 0.45 to 0.76. The examination of the inter-correlations among the items under each corresponding question indicated high correlations and strong bonds, as well as confirmed the evidence of internal consistency.

Since some of the responses under the questions were not integer after converting to the average values, a new scale based on the created indices which expressing new predictor variables is presented as following:

Three items were used to measure an individual's acceptance of speeding and each consisted of a statement and a four-point response scale, e.g.

'How acceptable do you personally think it is for a driver to: drive 10 mph over the speed limit on a city street? Or drive 10 mph over the speed limit on a freeway? Or drive 10 mph over the speed limit on a rural gravel road?'

Never 1 2 3 4 Always

After the conversion, the response of this question ranged continuously from 1 to 4. For instance, a response of 1.33 indicated a participant considered speeding on a city street/freeway/rural gravel road “never to seldom” acceptable.

It is noted that cases with missing data were involved in this process. Incomplete information was due to the absence of participants' answers to some items under a certain question, and the system failure during data collection process. However, simply deleting the incomplete cases would lead to a loss of observed information and produce biased statistical parameters when the missing cases are not random (Schafer, 1997). Therefore, based on the listwise deletion method, which includes an entire record if only single value is missing, a similar method for handling the missing cases was developed to retain as many valuable observations as possible. Specifically, the observations were kept if the majority (beyond 50%) of the items under a question were answered. For instance, if two of the three (2/3) items (drive 10 mph over the speed limit on a city street, and drive 10 mph over the speed limit on a freeway) under one question (how acceptable do you personally think it is for a driver to speed) were responded, the responses would be retained and averaged by two. On the other hand, if only one of four (1/4) or none of the (0/4) items was answered; it would be discarded as a missing case.

Differing from perceptions and acceptance, the experience with speeding (Cronbach's $\alpha=0.3438$), RLR (Cronbach's $\alpha=0.2399$), and DWA (Cronbach's $\alpha=0.1327$) with low the Cronbach's α coefficients that ranged from 0.13 to 0.34, were not shown to be valid for the index. As noted in the experience with speeding, Q21 (h) was uncorrelated with other items and could be removed from the analysis. The Cronbach's α increased to 0.4682 after deleting this uncorrelated item, however, the internal consistency for this index was still weak. It is also observed from the inter-correlation matrix (see Table 3-3) that the items under one concept (e.g., experience with RLR) are not closely related with each other and the internal consistency is weak. Thus, these three predictor variables were measured with another approach and discussed next.

3.3.3 Dummy coding

As mentioned in the previous section, the predictor variables of those representing the experience with aggressive driving behaviors acted out by adults Iowans were not valid for the index. To make them meaningful, dummy variables which take the value 0 or 1 to indicate the presence or the absence of some impacts (DrAPER & Smith, 1998) were created. In this study, dummy variables were used to sort data into two categories of action and non-action of the aggressive driving behaviors. For instance, a numerical value 1 represented the engagement of such a behavior; on the contrary, 0 represented no engagement. Again, the dummy variables were converted for the predictor variables of experience with DWA, RLR, and speeding, individually. Finally, the number of items that indicated by 1 (have participated in aggressive driving

behaviors) were summed, to indicate how many of the items were involved in a certain behavior and to make the predictors even stronger.

The descriptive statistics after data measurements and with the inclusion of demographic information is presented Table 3-3 as following.

Table 3-3: Descriptive Statistics After Data Measurements

Variable	Variable Description	Response Frequency	Min/Max	Cases (missing)
Speeding				
SPer (Perception of Speeding)	Q20. Rate your perception of speeding through a yellow traffic light/driving 10 miles per hour over the speed limit on a major highway/ on a city street/ on a rural gravel road from [Never (1)-> Once a month (2)-> Few a month (3)-> Few a week (4)-> Everyday (5)]	1-1.99: 5.9% 2-2.99: 23.2% 3-3.99: 37.2% 4-4.99: 27.9% 5: 5.1%	1/5	8
SAcc (Acceptance of Speeding)	Q19. Rate the acceptance of a driver driving 10 mph over the speed limit on a city street / freeway /rural gravel road from [Never (1)-> Seldom (2)-> Sometimes (3)-> Always (4)]	1-1.99: 64.3% 2-2.99: 27.8% 3-3.99: 7.6% 4: 0.1%	1/4	2
SPAt (Permissiveness towards Speeding)	Q18c. How serious you think excessive speeding is a threat to traffic safety? [1: Very, 2: Somewhat, 3: Slightly, 4: Not at all]	1. 69.9% 2. 24.5% 3. 4.2% 4. 0.9%	1/4	4

Table 3-3 continued: Descriptive Statistics After Data Measurements

Variable	Variable Description	Response Frequency	Min/Max	Cases (missing)
SExp (Experience with Speeding)	Q21. How many of the following behaviors have you participated in? e. asked by a passenger to slow down or drive more carefully while driving f. driven 10 mph over the speed limit on a highway or interstate g. on a city street h. on a rural gravel road j. Felt pressure from other drivers to drive faster	0. 25.5% 1. 38.1% 2. 20.1% 3. 7.4% 4. 2.4% 5. 0.6%	0/5	60
Red Light/Stop Sign Running (RLR)				
RPer (Perception of RLR)	Q20. Rate your perception of driving through red lights on purpose/ driving through a stop sign/ turning right at a red light without stopping from [Never (1)-> Once a month (2)-> Few a month (3)-> Few a week (4)-> Everyday (5)]	1-1.99: 22.0% 2-2.99: 39.3% 3-3.99: 24.2% 4-4.99: 11.5% 5: 2.0%	1/5	11

Table 3-3 continued: Descriptive Statistics After Data Measurements

Variable	Variable Description	Response Frequency	Min/Max	Cases (missing)
RAcc (Acceptance of RLR)	Q19. Rate the acceptance of a driver driving through a light that just turned red, when they could have stopped easily/ driving through a stop sign if the way looks clear/ making a right turn at a red light without stopping from [Never (1)-> Seldom (2)-> Sometimes (3)-> Always (4)]	1-1.99: 88.7% 2-2.99: 10.3% 3-3.99: 1.0% 4: 0.0%	1/3.6 7	0
RPA (Permissiveness towards RLR)	Q18b. How serious do you think people running red lights a threat to traffic safety? [1: Very, 2: Somewhat, 3: Slightly, 4: Not at all]	1: 83.9% 2: 12.4% 3: 2.6% 4: 0.8%	1/4	3
RExp (Experience with RLR)	Q21. How many of the following behaviors have you participated in? j. Driven through a light that has just turned red, when you could have stopped safely k. Sped up to get through a yellow light before it changed l. Turned right at a red light without stopping m. Driven through a stop sign	0. 40.0% 1. 43.8% 2. 9.6% 3. 1.4% 4. 0.6% 5. 0.0%	0/4	52

Table 3-3 continued: Descriptive Statistics After Data Measurements

Variable	Variable Description	Response Frequency	Min/Max	Cases (missing)
Driving with Aggression (DWA)				
APer (Perception of DWA)	20. Rate your perception of honking at other drivers/ speeding through a yellow traffic light/ tailgating other vehicles/ becoming visibly angry at something another driver did from [Never (1)-> Once a month (2)-> Few a month (3)-> Few a week (4)-> Everyday (5)]	1-1.99: 9.3% 2-2.99: 30.1% 3-3.99: 36.0% 4-4.99: 21.6% 5: 2.7%	1/5	4
APAt (Permissiveness towards DWA)	Q18b. How serious do you think aggressive driving is a threat to traffic safety? [1: Very, 2: Somewhat, 3: Slightly, 4: Not at all]	1: 66.5% 2: 27.7% 3: 4.2% 4: 1.2%	1/4	5
AExp (Experience with DWA)	Q21. How many of the following behaviors have you participated in? t. Tailgated another vehicle u. Became extremely angry at something another driver did v. Honked at other drivers w. Tried to avoid driving on a certain road because you felt it was dangerous	0. 36.4% 1. 35.8% 2. 16.6% 3. 6.1% 4. 0.4% 5. 0.0%	0/4	52
Demographic Characteristics				
Gender	Q38. And you are... 1. Male 2. Female	1: 41.8% 2: 58.2%	1/2	0

Table 3-3 continued: Descriptive Statistics After Data Measurements

Variable	Variable Description	Response Frequency	Min/Max	Cases (missing)
Age	Q39. What is your current age? 1. 18-25 years old 2. 26-39 years old 3. 40-64 years old 4. 65 and older	1: 5.8% 2: 14.4% 3: 47.8% 4: 31.3%	1/4	8
Vehicle Mile Traveled (VMT)	Q2: During the last year, in a typical 7-day week, about how many miles did you drive? 1. None 2. Less than 20 miles 3. 20-99 miles 4. 100-199 miles 5. 200-499 miles 6. 500-999 miles 7. 1000 miles or more	1: 0.3% 2: 7.2% 3: 32.3% 4: 22.6% 5: 21.2% 6: 5.1% 7: 5.3%	1/7	66

After obtaining the meaningful data, statistical modeling technique is required to perform analysis for the variables that predict an individual's behaviors of aggressive driving. SEM which was mentioned in chapter 2 for the application of psychological theories (Efrat & Shoham, 2013) will be used in this study, and its specification, estimation, evaluation, and application are discussed in the next section.

3.4 Structural Equation Modeling (SEM)

Structural equation modeling (SEM) is a multivariate statistical modeling technique that has served as an important analytical tool since the 1970s (Golob, 2003). Differing from an exploratory methodology, it is more confirmatory to assess the quantitative relationships among latent (unobserved) variables, which in turn are linear combinations of the measurement (observed) variables. Path analysis as described by Duncan (1975) and others can be thought of as a special case of SEM, the case where latent variables are also the observed variables and there are no attempts to adjust for measurement error.

According to Golob (2003), SEM has significant advantages over other linear-in-parameter statistical methodologies because they (1) allow random endogenous and exogenous variables to be measured with error (measurement errors), (2) the variances and covariances of latent variables are estimated based on the strength of the variances and covariances of their multiple indicators, and (3) measurement errors and specification errors separation can be estimated. In addition, (4) it is possible to test the overall fit of the model to the data, (5) examine mediating variables, (6) estimate the strength of correlations among error-terms, (7) estimate coefficients across multiple groups, (8) estimate dynamic phenomena with panel data, (9) accommodate missing data, and (10) adjust estimates to accommodate non-normal data.

3.4.1 Model specification

An SEM consists of two types of variables: observed and latent (unobserved), which constitute up to three sets of simultaneous equations: (1) a measurement model for the endogenous dependent or mediating variables, (2) a measurement model for the exogenous (independent) variables, and (3) a structural model that combines the first two sets of equations into a single set of simultaneous equations. As a matter of convention, latent variables are denoted by ellipses in the structural equation model (see Figure 3.1), while observed variables are denoted by rectangular boxes. The errors/residuals are conceived of as latent variables and denoted by small ellipses. Hypothesized predictive paths are represented by directed arrows from one exogenous predictor to the dependent variables directly or through a third mediating variable. Associations or correlations (covariances) between variables are represented by arrows with two directions. A sample of path (flow) diagram with SEM symbolizations is presented in Figure 3.1.

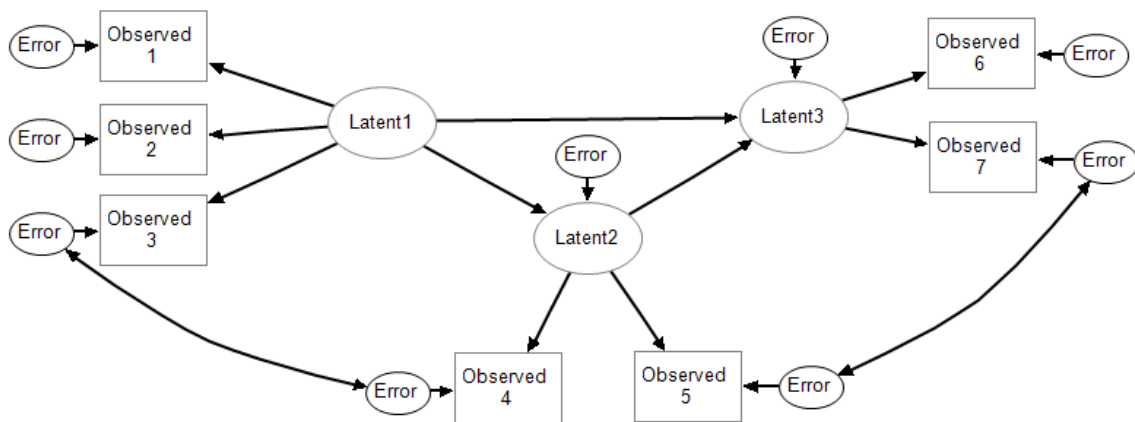

Figure 3.1 Example of path (flow) diagram with SEM symbolizations

An SEM measurement model is used to examine the linear relationships between latent (unobserved) variables and other variables in the system. Other variables could

either be observed variable which are often referred to as “indicators”, or unobserved variables specified by the “indicators” during the construction process. In SEM, any of the factor parameters could be restricted to zero or equal to others that are not zero. Similarly, covariance among the unexplained portions of both the observed and latent variables could also be specified as non-zero depending on modeler’s theoretical arguments or other judgments.

Among its many strength, a SEM is designed to test the regression effects of the exogenous variables on the endogenous variables, as well as the causal influences among endogenous variables. Again, error terms covariance could also be correlated in the structural model by a modeler. The structural model is allowed to have latent endogenous variables if observed endogenous variables are involved in a measurement model. The same principles also apply on exogenous variables.

Since the structural relations are presented by a series of regression simultaneous equations, the expression of each measurement equation is shown as (Bollen, 1989):

$$y_i = \Lambda_y \eta_i + \varepsilon_i$$

where $y_i = (y_{i1}, \dots, y_{ip})'$ is the vector of indicators; $\Lambda_y = p \times m$ factor loadings matrix; $\eta_i = (\eta_{i1}, \dots, \eta_{im})'$, $m \leq p$, is the underlying m vector of latent variables; ε_i is the measurement error term, with dimensions $p \times 1$.

On the other hand, the structural model which focuses on the relationships among latent variables can be expressed as (Bollen, 1989):

$$\eta_i = B \eta_i + \zeta_i$$

where $B = m \times m$ matrix that describes the relationships among latent variables in η_i and the diagonal elements are all zero; $\zeta_i = m \times 1$ vectors that represents the unexplained parts of η_i .

For interpretation purpose, it is a popular convention to report the standardized results so that the intercept is not included in the equation. The results of standardized parameters which only account for the magnitudes and standardize the different units of the variables will be discussed in the next chapter.

The SEM equations are based on the variance–covariance matrices of the endogenous and exogenous variables. The general principle of estimation is that the elements of the variance-covariance matrix are generated by the hypothesized model, so that the variances and covariances between observed variables can be interpreted as arising out of the structural model. A good fitting model will be one where the variance-covariance matrix generated by the model will accurately reproduce the observed variances and covariances of the sample (Golob, 2003). Taking the structure shown in Figure 3.1 as an example, the matrices for the observed and latent variables could be simply written as:

Measurement matrix:

Variance-covariance for measurement matrix:

$$\begin{bmatrix} y_1 \\ y_2 \\ y_3 \\ y_4 \\ y_5 \\ y_6 \\ y_7 \end{bmatrix} = \begin{bmatrix} 1 & 0 & 0 \\ * & 0 & 0 \\ * & 0 & 0 \\ 0 & 1 & 0 \\ 0 & * & 0 \\ 0 & 0 & 1 \\ 0 & 0 & * \end{bmatrix} * \begin{bmatrix} \eta_1 \\ \eta_2 \\ \eta_3 \end{bmatrix} + \begin{bmatrix} \varepsilon_1 \\ \varepsilon_2 \\ \varepsilon_3 \\ \varepsilon_4 \\ \varepsilon_5 \\ \varepsilon_6 \\ \varepsilon_7 \end{bmatrix} \text{ and } \Theta = \begin{bmatrix} \theta_{11} & 0 & 0 & 0 & 0 & 0 & 0 \\ 0 & \theta_{22} & 0 & 0 & 0 & 0 & 0 \\ 0 & 0 & \theta_{33} & 0 & 0 & 0 & 0 \\ 0 & 0 & \theta_{43} & \theta_{44} & 0 & 0 & 0 \\ 0 & 0 & 0 & 0 & \theta_{55} & 0 & 0 \\ 0 & 0 & 0 & 0 & 0 & \theta_{66} & 0 \\ 0 & 0 & 0 & 0 & \theta_{75} & 0 & \theta_{77} \end{bmatrix}$$

Structural matrix:

Variance-covariance for structural matrix:

$$\begin{bmatrix} \eta_1 \\ \eta_2 \\ \eta_3 \end{bmatrix} = \begin{bmatrix} 1 & 0 & 0 \\ \beta_{21} & 1 & 0 \\ \beta_{31} & \beta_{32} & 1 \end{bmatrix} * \begin{bmatrix} \eta_1 \\ \eta_2 \\ \eta_3 \end{bmatrix} + \begin{bmatrix} \zeta_1 \\ \zeta_2 \\ \zeta_3 \end{bmatrix} \text{ and } \Phi = \begin{bmatrix} \phi_{11} & 0 & 0 \\ 0 & \phi_{22} & 0 \\ 0 & 0 & \phi_{33} \end{bmatrix}$$

Even though SEM has many advantages among the statistical models, there are still some problems with the use of this technique. The fundamental concern when it comes to estimating SEMs is that whether they are identified. To be identified, it requires that the variance-covariance matrix is full rank and the inverse matrix exists. If the matrix is less than full-rank, the model is under-identified and there is no unique solution. Conversely, an over-identified model is the one in which more than one combination of parameter estimates (i.e., more than one model) will reproduce the same covariance (Golob, 2003). The detection of identification problems that based on an examination of the rank of the information matrix is not guaranteed, so that it might result in inaccurate estimates or failure of converging to a solution (McDonald, 1982). However, identification problems can also be diagnosed by re-estimating the model with an alternative initial solution, substituting the model-reproduced variance–covariance matrix with a sample matrix, or using methodologies provided by modern computer algebra (Bekker, Merckens, & Wansbeek, 1994).

3.4.2 Model estimation

With the knowledge of the model's foundations, several estimation methods such as normal-theory ML, weighted least squares (WLS), and generalized least squares (GLS) could be utilized. Among all, Maximum Likelihood (ML) is the most commonly used method in SEM estimation for its maximized probability of variance–covariance

generation and assumption of a multivariate normal distribution. The ML estimators account the effect of normality violations, sample size, non-convergence, and improper solutions (Bollen, 1989).

SAS software, an advanced analytical tool in statistics, is used to perform path analysis through its function of PROC CALIS statement. During the estimation procedure, ML estimation which is the default method provided by the software is applied, and the results are expressed in standardized terms for their simplicity of interpretation when the metrics of the items are not well understood.

3.4.3 Model evaluation

In order to determine whether a model is appropriate for a certain dataset, many criteria should be examined to evaluate overall goodness-of-fit (GOF) of SEM models, and compare one model with another. Since most of evaluation criteria are based on the chi-square statistic which is obtained from the optimized fitting function and sample size, it is the first indicator to be evaluated. Chi-square is a measure of fit that tests the difference of variance–covariance matrix between the observed one and the model-reproduced one; so that the level of statistical significance reveals the probability of the differences which resulted from sampling variation. Generally, a chi-square that smaller than two times of its degrees of freedom, which equal to the number of parameters that are free to vary (Ullman, 1996), is considered as a good fit.

Because the chi-square is sensitive to sample size and the number of parameters being estimated, two most widely recognized GOF measures have been proposed to neutralize the effects of sample size and penalize models which estimate too many

parameters. These measures, based on chi-square statistic, include: (1). Root mean square error of approximation (RMSEA) measures the discrepancy per degree of freedom (Steiger & Lind, 1980) and is noted as:

$$RMSEA = \sqrt{\frac{T - df}{(N - 1)df}}$$

where: $T \sim \chi^2_{(df)}$ and N is the sample size. From the expression, it is clear to see that as the chi-square approaches to zero, the index is closed to zero. As a rule of thumb, a RMSEA value of smaller than 0.05 or 0.06 in a 90% confidence interval is suggested (MacCallum, Browne, & Sugawara, 1996); (2) in the fact that models with more free parameters tend to yield better fit, root mean square residual (RMSR) is one of the indices that penalize models for the number of parameters, noted as:

$$RMSR = \sqrt{\frac{\sum_{i < j} (r_{ij})^2}{\frac{p(p + 1)}{2}}}$$

where: r_{ij} is the standardized differences between the observed and expected residuals and ranges from 0 to 1, and a RMSR value under 0.05 or 0.06 indicated a good fit (Byrne, 2001).

Additional GOF measures which assess the proportional chi-square reduction in an independence model comparing to the proposed model, or directly from the sample and the reproduced variance–covariance matrices of models include: (1) comparative fit index (CFI) that an estimation value close to or greater than 0.95 indicates a good model fit; (2) adjusted goodness-of-fit index (AGFI) which adjusts GFI for the degrees of

freedom in the model by additionally taking number of parameters estimated into account, an estimation value close to 1.0 (usually above 0.95) is considered a good fit.

Other than discussed above, many other measures could also be used to evaluate the overall fit of models. In this study, measures such as chi-square, RMSR, RMSEA, AGFI, and CFI are used particularly to provide the basic criteria for model assessment, comparison and selection, which will be presented in the next chapter.

3.4.4 Model application

For the application of this technique, researchers indicate that SEM has been used to predict travel behavior since 1980. The earliest models were used to analyze travel demand such as vehicle ownership and usage (Den Boon, 1980), and a dynamic analysis on the mode choice and attitude–behavior response (Lyon, 1981). In the 1990s, SEM was widely used to estimate the causal links among attitudes, perceptions, stated behavioral intentions, and actual choice behavior on travel modes and support for policies. The application of SEM to driver behavior also has been growing rapidly during these years. Donovan (1993) explored the risky behaviors with DUI of alcohol; Golob and Hensher (1996) studied the behavior of long-distance truck drivers under drug taking; and Ng and Mannering (1999) examined drivers' speeding behavior when they were receiving different advisory information.

In addition, a preliminary study using the same Iowa public survey questionnaire was conducted to explore the culture of distracted driving among adult Iowans in 2013. Li, Gkritza, & Albrecht (2013) applied SEM technique by establishing four latent variables: distractibility (DB), self-reported distracted driving behavior (SDDB),

personal acceptability for distracted driving (PADD) and prediction of possible accidents (PPA) to test respondents' experience and attitudes towards distracted driving, as well as to examine the relationship among their socioeconomic and demographic groups. The results from SEM models indicated high correlations between respondents' experience and attitudes on distracted driving, and also that their age and household income were strong indicators of distracted driving behavior.

3.5 Summary

This chapter first discussed the Iowa public opinion questionnaire survey and provided the brief results related to various aggressive driving behaviors. The general results showed that most of adult Iowans were satisfied with the traffic safety in Iowa, and they had different perceptions, practices and accepting/permissive attitudes towards speeding, RLR, and DWA.

Secondly, this chapter presented the measurements of survey questions related to aggressive driving behaviors including recoding, creating indices, and dummy coding. In order to make stronger indicators, the raw responses from the questionnaire were recoded into an ascending order that higher scores indicated higher aggressive inclinations. Several indices including the acceptance and perception of each aggressive behavior were created based on the correlation, reliability and association of the items under corresponding questions. Moreover, dummy variables were developed for the experience with the behaviors. The measurement of handling missing cases was also discussed.

Lastly, this chapter also introduced SEM technique which used to establish statistical models. Model specification was illustrated, where the identification and correlation problem in SEM was addressed, followed by model estimations through SAS software using ML method. In order to establish models in good fits, several parameters including chi-square, RMSE, RMSEA, AGFI, and CFI were demonstrated to evaluate and criticize the models. Besides, the applications of SEM on transportation safety were studied, and a discussion of the preliminary study using the same dataset to analyze distract driving behavior in Iowa was also included.

The summary of questionnaire results on traffic safety, current driving perceptions, accepting/permissive attitudes, and practices, as well as demographics and socio-economic status offered in this chapter will provide the direction for the data analysis. The methodology of SEM will be applied on the analysis of aggressive driving behaviors and facilitate the estimation of statistical models; the descriptive results and the results obtained from SEM models will be shown in the next two chapters.

CHAPTER 4

DESCRIPTIVE RESULTS

4.1 Overview

This chapter presents the detailed descriptive results related to aggressive driving behaviors and the key findings from demographic-and socioeconomic-status.

4.2 Aggressive Driving Statistics

As indicated in earlier chapters, aggression is one of the prominent types among risky driving behaviors and has become a growing problem worldwide. With respect to reducing risky and aggressive driving in Iowa, a series of survey questions was designed to identify risky and aggressive driving behaviors, examine the perceptions and acceptance of these behaviors, and explore the practices of behaviors such as DWA, speeding, and RLR. Questions and responses related to the three specific behaviors are presented in detail in the following subsections.

4.2.1 Speeding

Speeding is considered one of the most important contributors to specific kinds of crashes active shunts, active reversing, right of way violations, and loss of control (West & Hall, 1997). In 2011, 12.5% of the drivers who involved in fatal crashes were driving too fast when the crashes occurred in Iowa (FARS, 2011). Most of the participants (94.4%) considered people driving with an excessive speed was either a very serious or somewhat serious threat to traffic safety, and the majority of adult Iowans (63.4%) reported that Iowa had done excellent and good in enforcing the speed limit.

In terms of acceptance, most adult Iowans considered that driving 10 mph over the speed limit on a city street (76.5%) or on a rural gravel road (64.5%) was never acceptable. Surprisingly, around half (41.4%) of them considered driving 10 mph over the speed limit on a freeway was sometimes acceptable. It can be seen from Figure 4.1 that participants' acceptance of speeding behavior varies from different road systems.

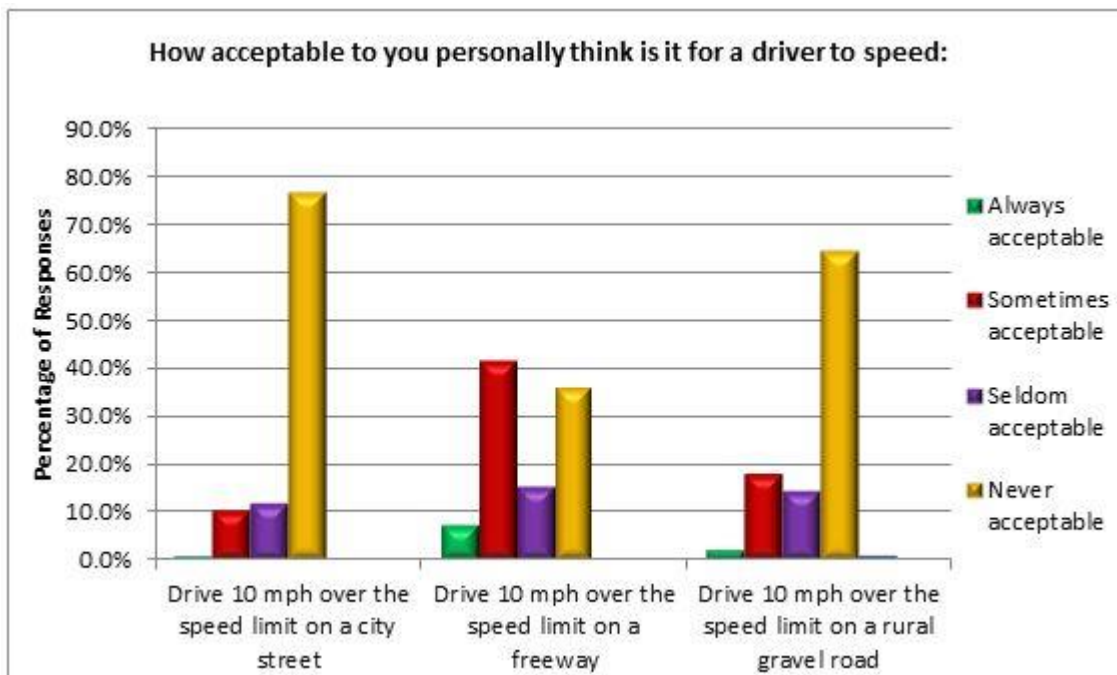

Figure 4.1 Acceptance of speeding behavior on different road classification systems

Although most of adults Iowans considered speeding to be a very serious and somewhat serious threat, over one-third (39.7%) of them strongly agreed or agreed with that the chance of being caught was small for speeding. In addition, almost one-third (29.6%) of them strongly agreed or agreed with that there wasn't much chance of an accident if they were careful when speeding. There were discrepancies between their opposed opinions on speeding and the agreeableness on punishments.

When they were asked about their own driving experience, most of the adult Iowans reported that they had not been asked to slow down by a passenger (83.4%), neither had they driven 10 mph over the speed limit on a city street (84.9%) and rural

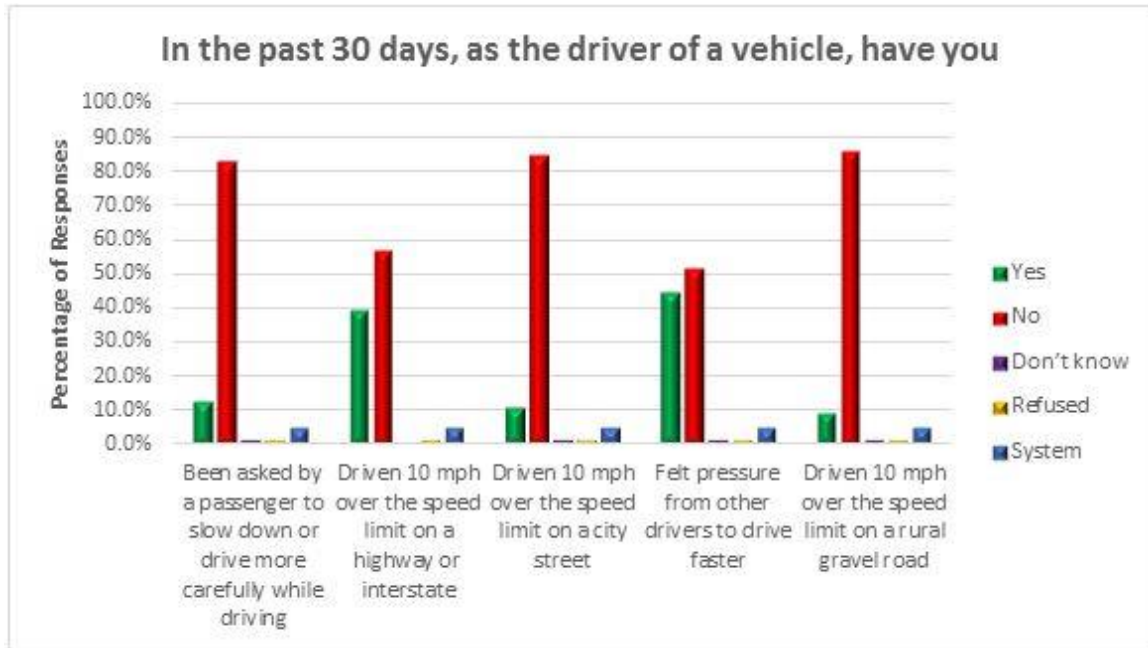

Figure 4.2 Driver's experience with speeding in past 30 days gravel road (85.9%). However, nearly 40% of the participants reported themselves having driven over 10 mph over the speed limit on a highway or interstate, and around 45% of them reported having felt pressure from other drivers to drive faster. The responses obtained from self-reported driving behaviors were surprisingly opposite from their opinions and attitudes towards speeding. Driver's experience with speeding is presented in Figure 4.2, where "system" represents the system missing values that the respondent was not asked the question due to the skipping of the question. The skipping was typically caused by the variable nesting in designing the instrument or the conditional logic statements programmed in the instrument.

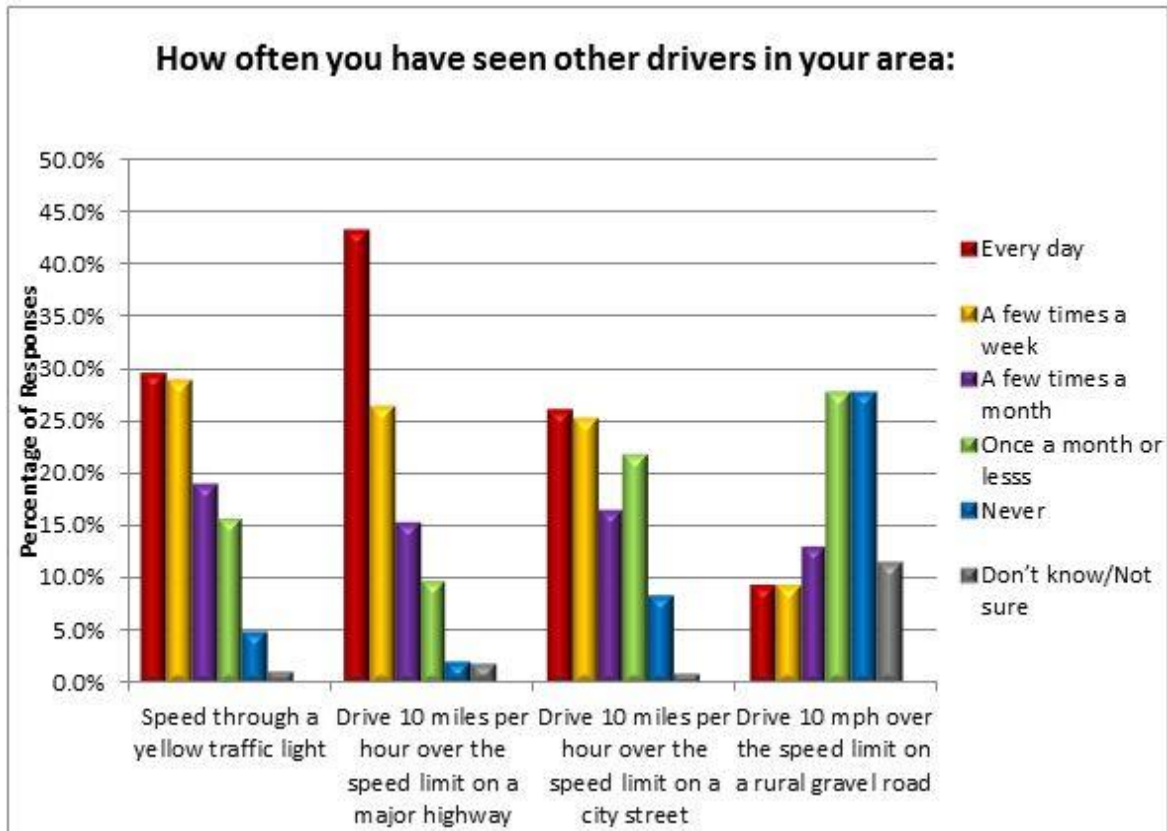

Figure 4.3 Perception of various speeding behaviors in the driver's area

Their perceptions on speeding were asked in the questionnaire as well.

Approximately half of the participants (43.4%) had seen other drivers driving 10 miles per hour over the speed limit on a major highway every day. Over a quarter of them had seen other drivers speeding through a yellow traffic light (29.7%) or driver 10 miles per hour over the speed limit on a city street (26.3%) every day. Similarly, more than one-fourth reported having seen other drivers speeding through a yellow traffic light (29.0%), driving 10 miles per hour over the speed limit on a major highway (26.7%), and driving 10 miles per hour over the speed limit on a city street (25.5%) a few times a week. The descriptive statistics indicated that speeding was not uncommon in Iowa, and

Iowans' perceptions on speeding behaviors also vary with the different road systems, as presented in Figure 4.3.

For those who have driven 10 mph or more over the speed limit in the past 5 years, about half (45.2%) of them reported a reason of keeping up with the flow of traffic, approximately one-fifth (17.8%) were not paying attention to the speed, and more than one-sixth (15.5%) reported themselves speeding for running late. The reasons for speeding are presented in Figure 4.4.

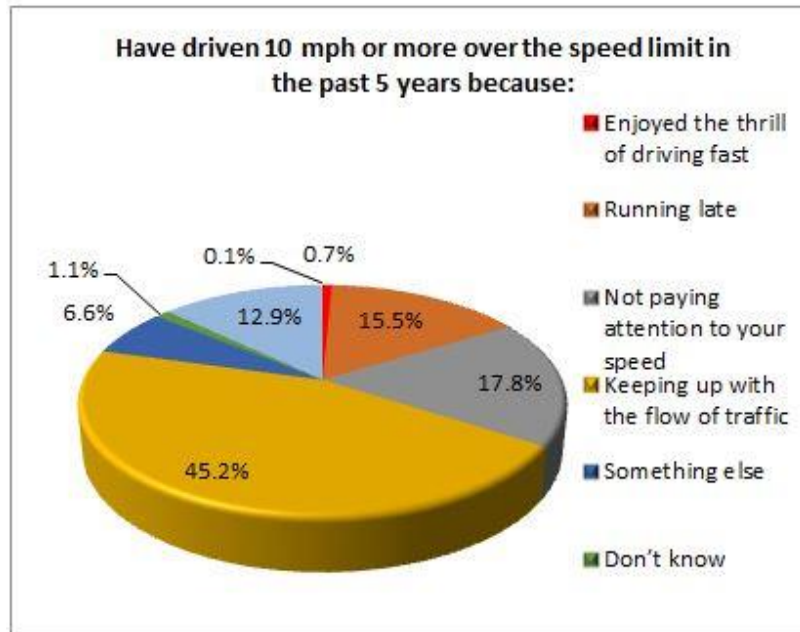

Figure 4.4 Reasons for speeding

In the questionnaire, opinions and attitudes towards using cameras to automatically ticket speeding were also covered. Only around half of the respondents supported using camera on major highway (54.6%) or city streets (55.8%), and 83.5% of them thought drivers would be more careful if they knew that speed/red light camera were in place. In addition, over one-third of them (37.3%) thought that the speed limit on a rural gravel road should be over 50 mph. It is interesting to note that the participants' opinions and attitudes towards speeding behavior did not match with the ones towards speeding enforcement.

4.2.2 Red-light running

RLR is fairly typical among aggressive driving behaviors and was an important contributor for 5.7% of the drivers who involved in fatal crashes in 2011 in Iowa, higher than the national level of 4.2% (FARS, 2011). Most adult Iowans (83.9%) rated people running red-lights as a very serious threat to traffic safety.

From the survey results, a majority of adult Iowans considered driving through a light that just turned red when they could have stopped easily (81.0%), driving through a stop sign if the way looked clear (85.7%), and making a right turn at a red light without stopping (78.7%) were never acceptable. The statistics indicated that participants' acceptance of RLR was fairly low.

When asking about their perceptions of other drivers' behaviors, around one-

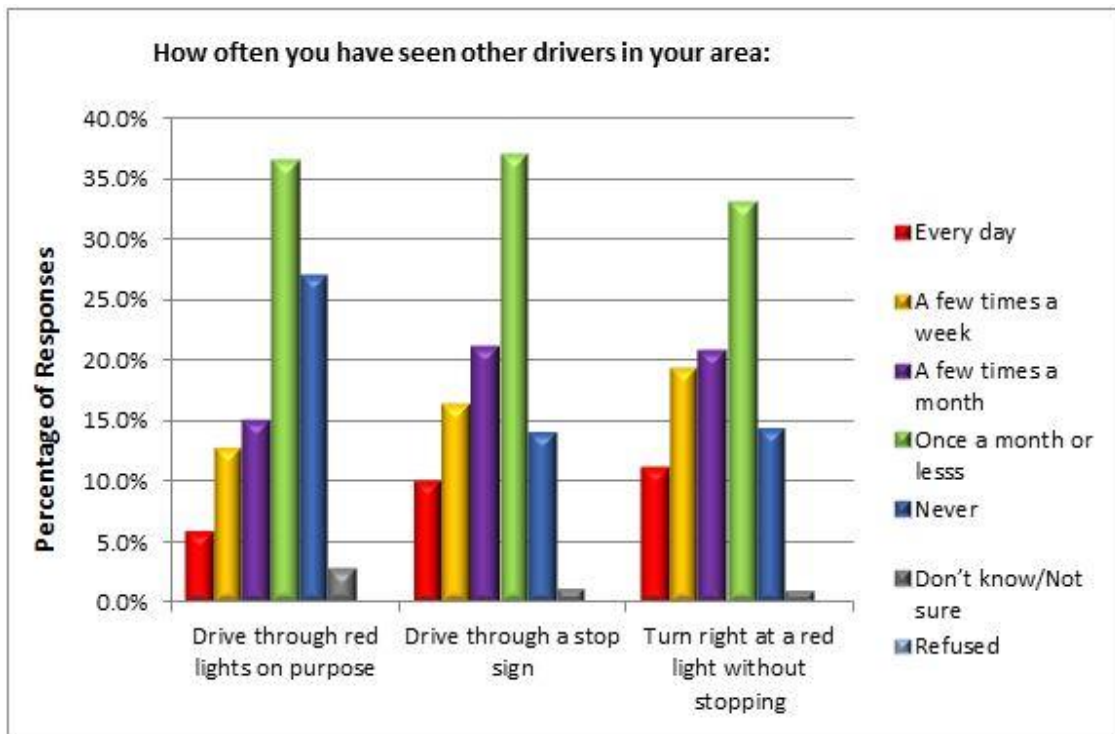

Figure 4.5 Perceptions of various RLR behaviors

tenth of the participants had seen drivers driving through a stop sign (10.0%) or turning right at a red light without stopping (11.2%) every day. Moreover, only 5.9% have seen people driving through red lights on purpose every day. The perceptions on RLR under different conditions are also distinctive, as shown in Figure 4.5.

Comparing to their perceived behaviors, most of adults Iowans reported that they had not driven through a light that just turned red when they could have stopped safely (88.5%), had not turned right at a red light without stopping (90.1%), and had not driven through a stop sign (87.5 %) in the past 30 days. Surprisingly, almost half of them (48.4%) have reported have been sped up to get through a yellow light before it changed. The responses obtained from self-reported driving behavior were quite the opposite ironically, since they reported higher frequency of other drivers' behaviors rather than their owns.

Moreover, approximately half (46.0%) of them strongly agreed or agreed with that the chance of being caught was small for RLR. The responses of their attitudes towards RLR enforcement were quite different from their opinions on the severity of such a behavior.

4.2.3 Driving with aggression

Aggressive driving behavior is defined as a more “intentional” and “hostile” driving behavior compared to other risky behaviors. In 2011, it was reported that 2.3% of the drivers involved in fatal crashes were driving in a reckless manner in Iowa.

Similar to speeding and RLR, most of the survey respondents (94.2%) considered DWA a very serious and somewhat serious threat to traffic safety.

In the survey, most of the adult Iowans (86.9%) reported that they had not tailgated another vehicle, more than two-thirds (68.8%) reported that they had not become extremely angry at something another driver did, and over three-fourth (76.5%) had not honked at other drivers. In addition, around one-third (34%) reported that they had tried to avoid driving on a certain road because they felt it was dangerous. The statistics from self-reported experience did not provide the strong evidence that they were driving aggressively in the past 30 days.

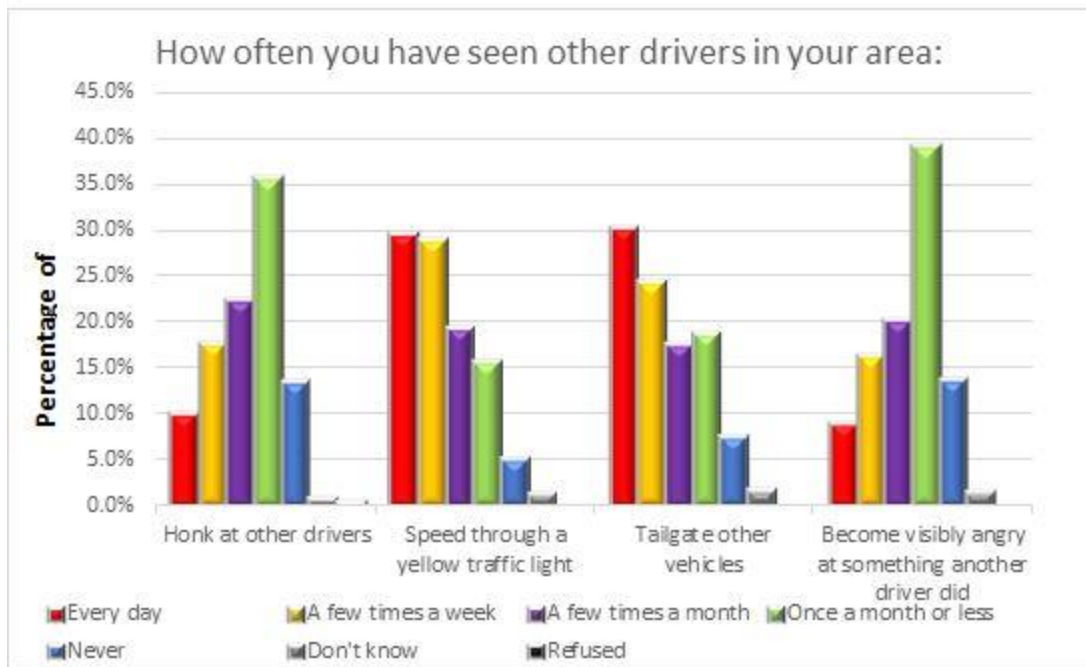

Figure 4.6 Perceptions of DWA

The perceptions of driving with aggression are shown in Figure 4.6. Comparing to their experience, one-tenth (10.0%) of the participants had seen drivers honking at

other drivers or becoming visibly angry at something another driver did (9.0%) every day. However, approximate one-third of them reported having seen drivers speeding through a yellow traffic light (29.7%) or tailgating with other vehicles (30.3%) every day. Again, they tended to report more of others' behaviors rather than their owns.

Interestingly, the overall estimation indicated that the participants held a more permissiveness attitude towards speeding and DWA, comparing to RLR. The acceptance of speeding behavior was also higher than that of RLR. In addition, the participants reported higher frequency of seeing other drivers speeding and behaving aggressively than seeing others running red-light. That might explain the reason why the respondents became more tolerant in speeding and DWA. As a result, the frequency of participating in speeding and aggressive behaviors on their own was higher than that of running red-light, based on the responses of their reported experience.

4.3 Demographic and Socioeconomic Characteristics

The participants consisted of 41.8% of males and 58.3% of females, varying from 18 to older than 65 years old. Approximately half of them (47.8 %) were middle-aged (40-64), about one-third (31.3%) were older than 65 years old, and the young adults had the smallest portion of 20.2%. They were selected from different residential areas from rural farms to large urban cities, and their education and income levels also varied.

4.3.1 Gender-oriented responses on aggressive driving behavior

According to the literature discussed in Chapter 2 (Wilson, 1990; Wilde, 1994; Retting et al., 1999; and Papadakaki et al., 2008), gender plays an important role in

analyzing aggressive driving behavior. Thus, there could be gender differences in perceived frequency, acceptance and permissiveness toward aggressive behaviors, as well as personal experience with speeding, RLR and DWA. Figures 4.7 and 4.8 show such differences.

Figure 4.7 presents the attitudes towards speeding between male and female. As shown, male drivers has a more permissiveness attitude towards speeding than female drivers. Same results were obtained when comparing the attitudes towards RLR and DWA by gender.

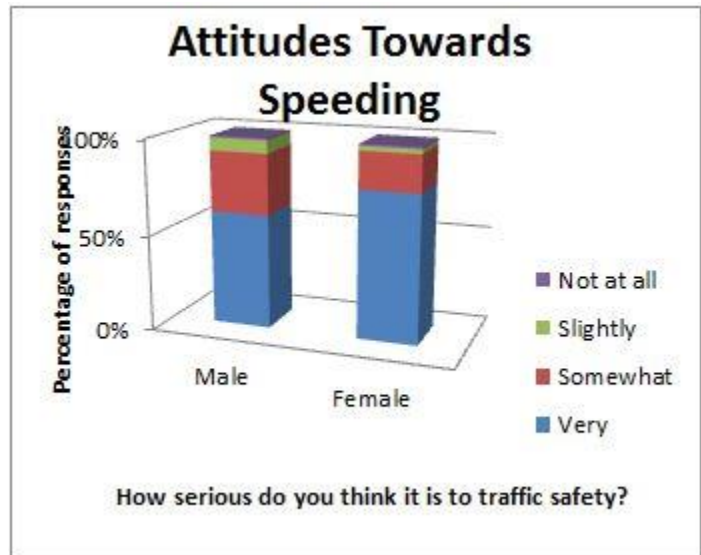

Figure 4.7 Attitudes towards speeding by gender

Figure 4.8 indicates the different RLR experience between male and female drivers. Apparently, male drivers (52.1%) self-report more experience with speeding through a yellow light than female drivers (45.8%).

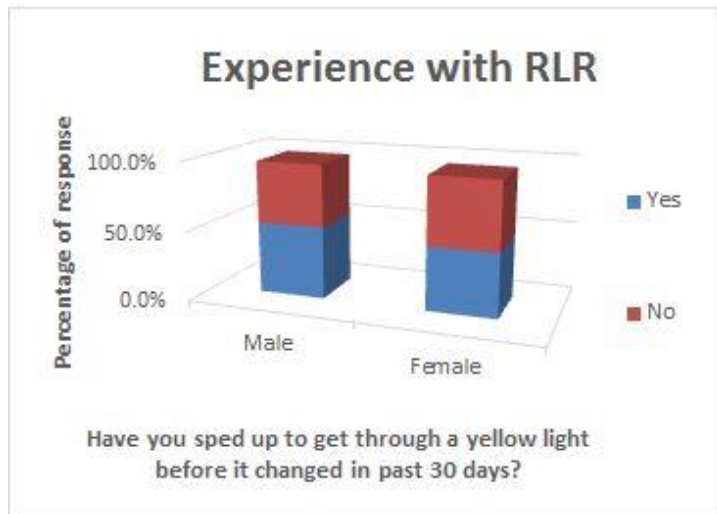

Figure 4.8 Experience with RLR in past 30 days by gender

In addition, male

participants reported driving 10 mph over the speed limit on a city street, freeway and rural gravel road as more acceptable than females. The acceptance for different cases of RLR and DWA was also higher among male drivers. Comparing to female, male drivers reported higher frequency of aggressive driving behaviors they had seen in their areas than females. As the graphs showed a similar pattern for acceptance and perception of aggressive driving behaviors, they are not presented here. The findings were in accordance with the assumption of that enhanced perceptions resulted in high behavioral intentions. The results also indicated that women were more responsible and careful while driving than men. Therefore, it is not surprising that the number of male drivers who reported to act out aggressive behaviors was higher than female drivers.

4.3.2 Age-oriented responses on aggressive driving behavior

Similar to gender, age is another important contributor of various responses among the participants. Four age groups were classified as: young (18 to 25 years old), mid-young (26 to 39 years old), mid-old (40-64 years old), and old (65 years or older). Figure 4.9 illustrates the attitude towards DWA by different age groups.

From Figure 4.9, young age group (18-25 years old) has a high permissiveness towards DWA than any other age groups, with lower percentage of respondents

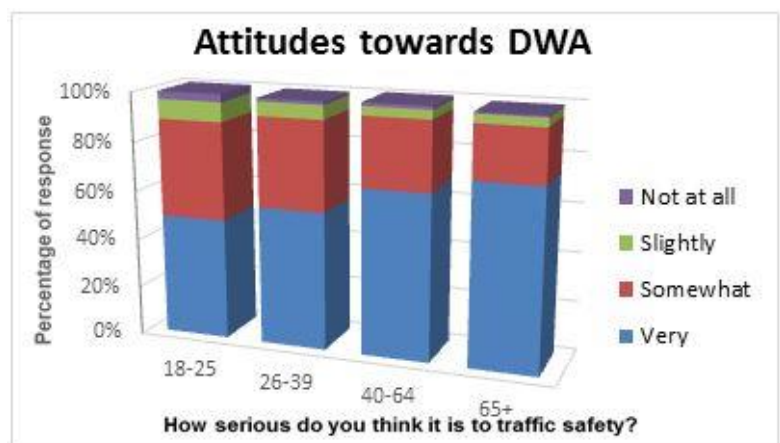
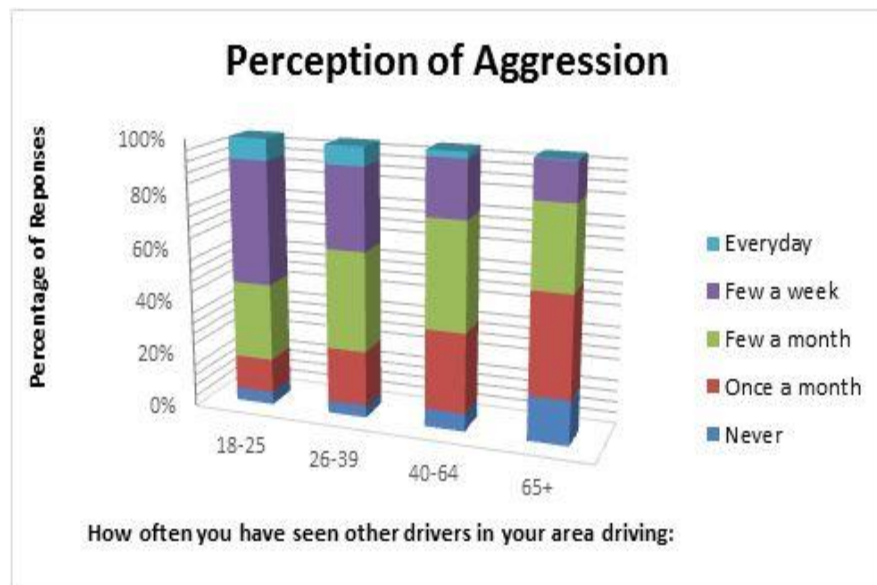

Figure 4.9 Attitudes towards DWA by different age groups

in this group rated DWA as a very or somewhat serious threat to traffic safety. Mid young age group (26-39 years old) is ranked as second permissive towards DWA after young age group. It could be observed that as age increases, the permission towards aggressive behavior decreases. These findings are also in accordance with the conclusions drawn from previous studies discussed in Chapter 2 (Wilson, 1990; Deery, 1996&1999; Retting et al., 1999; Clarke et al., 2002; Letirand and Delhomme, 2005; Hutchens et al., 2008; Machin and Kim, 2008; Hanna et al., 2013; Harbeck and Glendon 2013).

Similar results were also obtained for the perception of speeding and RLR. Young age group has seen these behaviors more frequently, and the perception



and the perception is decreasing as age increasing, as shown in Figure 4.10. Young age group had more experience with aggressive behaviors over the past 30 days than other groups. Again, the experience with aggressive driving shows a declining trend with age. The graph pattern of DWA experience was similar to perception and will not be presented in detail.

4.3.3 Socioeconomic, residential, and travel history on aggressive driving

Apart from demographic characteristics, socioeconomic status such as education, income, residential types, and travel information might have some sort of influences on aggressive driving as well, and their descriptive statistics are examined and presented in the subsections.

4.3.3.1 Education

Apart from age and gender, differences in education level could also result in different attitudes towards aggressive driving behaviors. Education was classified into six groups based on the respondent's highest degree received: elementary (1.2% of Grade 1-8), mid-high school (1.9% of Grade 9-11), high school (29.9% of Grade 12 or GED), community college (32.1% of College 1-3 years), college (24.4% of College 4 years), and graduate (10.4% of Graduate degree). There was an ambiguous pattern observed on the trend of perception, acceptance/permissiveness, and experience at this stage of analysis. Thus, it was difficult to determine whether the respondents with lower education were more aggressive. Participants with a college degree had highest acceptance and held the most permissiveness towards speeding, RLR, and DWA. However, those who received a middle school degree showed the highest perceptions of aggressive driving behaviors, and they self-reported the highest frequency of engaging in these behaviors. Therefore, there was no evidence to show which group was more careful and responsible while driving.

4.3.3.2 Income

An individual's income level is significantly reflected by his/her education, and it has similar influences on the responses of the participants. Five age groups were classified as: low (18.0% of less than \$25K), mid-low (24.3% of \$25K to less than \$50K), middle (18.8% of \$50K to less than \$75K), mid-high (13.8% of \$75K to less than \$100K), and high (14.1% of \$100K or more). Similar to education, an ambiguous pattern in the descriptive statistics was found to identify the most aggressive driving groups. The participants with an income over \$50,000 held relatively less permissiveness towards speeding, RLR, and DWA than the lower income groups. Moreover, the highest income group (over \$100,000) had the highest acceptance of speeding among other groups, which might be due to their value of time. Those who had an income over \$50,000 also reported seeing more aggressive driving behaviors every month than the lower income groups. However, the lowest income group (under \$25,000) had the highest experience with being aggressively while driving than other groups. It is complicated to identify the most aggressive participants from income groups.

4.3.3.3 Residential type

The distinctive attitudes towards, acceptance of, perceptions of, and experience with speeding, RLR, and DWA would be affected by participant's residential area as well. The residential types could be classified into five groups as: rural (22.6% of a farm or an open rural area), small town (27.8% of population less than 5,000), large town (16.8% of population 5,000 to less than 25,000), small city (10.0% of population 25,000 to less than 50,000), and large city (22.2% of population 50,000 or more). Descriptive statistics illustrated that the participants living in urban areas had a relatively less

permissiveness attitude towards speeding, RLR and DWA than rural participants. However, not many differences were observed in the acceptance between urban and rural participants, with a slightly higher acceptance found among urban participants. Urban residents living in the large cities had the highest perceptions on the identified three aggressive driving behaviors than the residents in other areas. The reported experience with DWA was approximately the same among urban and rural residents, with the lowest frequency observed in large towns. Again, no clear evidence was found to identify the most aggressive driving groups by analyzing residential types.

4.3.3.4 Vehicle miles traveled (VMT)

The range of vehicle miles that the participants traveled during a typical 7-day week was reported from 0 to more than 1,000 miles.

The analysis indicated that people who drove more miles weekly were more permissiveness towards speeding, RLR, and DWA. The acceptance of

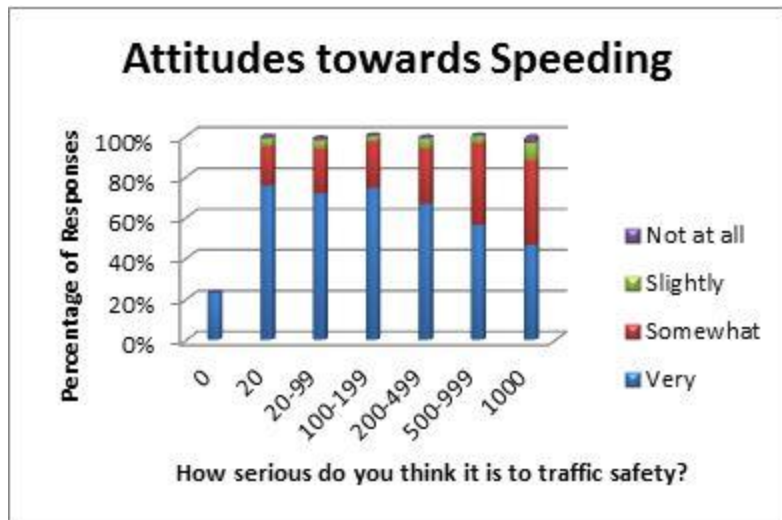

Figure 4.11 Attitudes towards speeding by VMT

the aggressive behaviors among the participants who drove 1,000 miles or more was much higher than the drivers who traveled less during a week. Similarly, both of their perceptions of and experience with driving aggressively were the highest. Figure 4.11 indicates the attitude towards speeding by different VMT of the respondents. The

perception and experience by different VMT showed a similar pattern as the graph shown in Figure 4.11, they are not presented repeatedly.

In summary, ambiguous patterns in aggressive driving behaviors were found among participants' socioeconomic groups. However, the travel history that measured by VMT revealed some trends of aggressive driving behaviors. The descriptive statistics of VMT showed that individuals who have driven higher mileage in a 7-day week tended to behave more aggressively than those who traveled less. The impacts of VMT will be analyzed in the statistical models in the next chapter.

4.4 Summary

The descriptive survey results showed that adult Iowans were more tolerated in speeding and DWA than in RLR. The descriptive statistics of demographic characteristics and socio-economic status including age, gender, education level, household income, residential area type, and VMT also illustrated that their driving attitudes, acceptance, perceptions, and behaviors were affected by their demographic characteristics, particularly by gender, age, and VMT. To be more precise, young males and people who traveled more tended to be more aggressive. The key findings from descriptive statistics suggest meaningful variables and assist constructing statistical models.

CHAPTER 5

MODEL RESULTS, IMPLICATION, AND APPLICATION

5.1 Overview

This chapter presents the results of models that applied the proposed version of TRA and were estimated by SEM techniques. For this application of the TRA, respondents were asked to acknowledge the extent to which they reported seeing aggressive behaviors such as DWA, RLR, and speeding, or the extent to which respondents perceived that the behavior existed (perception). Respondents' perceptions of these specific driving behaviors were hypothesized to affect the extent to which they expressed accepting (acceptance) and permissive (permissiveness) attitudes toward these behaviors, which in turn would affect the extent to which they were willing to personally experience or engage in the behaviors (experience). Based on the available data in this study, several modifications were made to the TRA and a proposed version of the TRA was used to construct models for the three identified aggressive behaviors (DWA, RLR, and speeding). Path analysis, which is a special case of SEM, was used to gain insights into the relationships among perception, acceptance/permissiveness, and experience. In this case, latent variables were also the observed variables and there were no attempts to adjust for measurement error.

During the construction process, three sets of conceptual models were developed based on the proposed version of the TRA. Firstly, the univariate behavior models for each individual behavior (DWA, speeding, and RLR) were built, separately. Secondly, the interactions and relations between any two of the three behaviors were analyzed

through three pairs (DWA and speeding, DWA and RLR, speeding and RLR) in bivariate behavior models. Finally, the perceptions of the frequency of the behavior, expressions of acceptance/permissiveness, and the reported personal experience with all three behaviors were included in trivariate behavior models to examine the relationship among these behaviors. For all of the behavior (univariate, bivariate, and trivariate) models, gender differences were considered. After that, demographic and traveling factors such as gender, age, and VMT were added to the trivariate behavior models to explore the differences among demographic groups in aggressive driving behaviors. In particular, as acceptance and permissiveness are similar indicators, they were analyzed in respective models.

In addition, as discussed in Section 5.4, several latent variables related to aggressive driving behaviors were established, and five alternative variations of SEMs were constructed to confirm previous results and validate the conceptual models. The models were evaluated, compared, and selected based on the estimated parameter coefficients and model fits.

The major findings were implied after obtaining the results, and several applications based on the main findings were presented and discussed.

5.2 Descriptive Statistics for Indices Used in Modeling

The observed variables and new indexes created in Chapter 3 were used in developing conceptual models which applied to the proposed version of TRA and employed SEM analysis. The detailed data description was presented in Table 3.2. Again, the variables of Perception, Acceptance, Permissiveness, and Experience will be

delineated in this thesis with capital letters, whereas the concepts of perception, acceptance, permissiveness, and experience will be distinguished with lower letter. Generally, perception is the respondents' perceptions about the frequency with which they observe the behavior in others. Higher scores on the scale of perception imply that respondents report seeing a large amount of aggressive behavior. The term acceptance measures the respondents' acceptability of various aggressive driving behaviors; and higher scores indicate that one finds such behavior highly acceptable. Similarly, the term of attitude is less about attitude than about the respondents' acceptance and expressions of permissiveness toward the aggressive behaviors. Higher scores clearly imply that respondents are more accepting of the behaviors and consider the behaviors permissible. In addition, experience also conveys the extent to which the respondents personally experience the aggressive behavior by engaging in it. Higher scores imply that participants report more instances where they drive with aggression, speed, and run red lights.

The descriptive statistics of predictor variables, as well as demographic factors, are presented in Table 5.1. Overall, higher scores after re-coding described in Chapter 3 indicated higher inclinations towards aggressive driving behaviors. For instance, a respondent who reported a score of 1 in speeding Experience was assumed to be less aggressive than one who reported 3. The age factor was sorted by different categories in an ascending order from young to old; for instance, a score of 4 implied the respondent was 65 years old or older while those who reported 1 were 18-25 years old. A mean value of 3.04 indicated that most participants were between 40-64 years old, which was

consistent with the survey responses that nearly half (47.8%) of them were 40-64 years old. A score of 1 indicated males and 2 indicated females in gender description, so a mean score value of 1.58 illustrated the participants consisted of 58% females. Higher scores in VMT represented higher mileage traveled, where 7 implied driving 1000 miles or more during a typical seven-day week and 1 implied the respondent did not drive at all. An average value of 4.00 showed that most participants traveled 100-199 miles weekly. The matrix presenting the correlations among all used variables is in Table 5-2.

Table 5-1: Descriptive Statistics for Indices Used in Models

Variable	Description	Mean	S.D.	Min/Max	Number of Observation
APer	Perception of DWA	3.14	0.93	1/5	1084
SPer	Perception of speeding	3.39	0.92	1/5	1080
RPer	Perception of RLR	2.61	0.99	1/5	1077
APAt	Permissiveness towards DWA	1.40	0.63	1/4	1083
RPAAt	Permissiveness towards RLR	1.20	0.51	1/4	1085
SPAAt	Permissiveness towards speeding	1.36	0.61	1/4	1084
RAcc	Acceptance of RLR	1.29	0.45	1/3.67	1088
SAcc	Acceptance of speeding	1.71	0.65	1/4	1086
AExp	Experience with DWA	0.93	0.92	0/4	1036
SExp	Experience with speeding	1.21	1.05	0/5	1028
RExp	Experience with RLR	0.73	0.75	0/4	1036
Age	Age	3.05	0.83	1/4	1080
Gender	Gender	1.58	0.49	1/2	1088
VMT	Vehicle Miles Traveled	4.00	1.28	1/7	1022

Table 5-2: Correlation Matrix of the Variables

	Perception			Permissiveness			Acceptance		Experience		
	APer	SPer	RPer	APAt	SPAt	RPAAt	SAcc	RAcc	AExp	SExp	RExp
APer	1										
SPer	0.656	1									
RPer	0.484	0.347	1								
APAt	-0.199	-0.387	0.037	1							
SPAt	-0.045	-0.050	-0.042	0.325	1						
RPAAt	-0.011	-0.014	-0.100	0.194	0.365	1					
SAcc	-0.112	0.072	0.111	0.200	0.287	0.085	1				
RAcc	-0.114	0.021	0.132	0.130	0.258	0.081	0.255	1			
AExp	0.396	0.386	0.185	-0.123	0.051	0.054	0.072	0.034	1		
SExp	0.197	0.234	0.260	0.095	0.135	0.004	0.438	0.190	0.275	1	
RExp	0.130	0.127	0.153	0.090	0.111	0.082	0.245	0.279	0.187	0.314	1

Note: the correlations were produced by the maximum likelihood (ML) method.

As shown in Table 5-2, the highlighted triangles show the correlations among the items within the constructs. The highlighted values are positive and significant, thus providing evidence of convergent validity. In other words, the correlation matrix indicates that the three behaviors (DWA, speeding, and RLR) under each subject (perception, acceptance, permissiveness, and experience) were highly correlated. The correlations among the perceptions of the three behaviors were the highest and ranged from 0.35 to 0.67, which were expected to provide excellent factor loadings in the SEM models. The correlations among three experiences ranged from 0.19 to 0.31 and were relatively weaker, which might result in lower factor loadings.

However, some of the correlations between constructs (shown in the un-highlighted rectangular boxes) were larger than the correlations within constructs. For instance, the correlation between speeding Acceptance and speeding Experience (0.438) was much higher than speeding Acceptance and RLR Acceptance (0.255). The correlation of RLR Acceptance with its Experience (0.279) was also higher than with speeding Acceptance (0.255). These correlations might become problems when it comes to estimating SEM structural models later on.

Based on the descriptive statistics of the predictor variables, as well as their correlations with each other, statistic analytical models could be constructed to examine the aggressive driving behaviors among adult Iowans. The next sections present the construction process and results of conceptual models, followed by five trials of SEM structural models.

5.3 Conceptual Model Construction and Results

To explore the relationships among respondents' perceptions of aggressive behaviors, their acceptance/permissiveness towards aggressive behaviors, and their own experience with various aggressive driving behaviors, several conceptual models were proposed based on the proposed version of the TRA and operationalized using a special case of SEM techniques discussed in Chapter 4.

Recall from Section 2.4.2, the TRA suggests that attitudes and subjective norms, collectively, affect one's intention to perform a certain behavior, and the intention predicts the actual behavior, as shown previously in Figure 2.5.

However, this study lacks the exact same predictor variables (attitude, subjective norm, behavioral intention, and behavior) proposed by the TRA. To apply this theory, several adjustments were made to better coordinate the theory with the data available in this study, and similar variables that approximately represented the ideas were used as proxies. Specifically, perception questions were substituted for "subjective norm" since the questions in the survey asked about the frequency of witnessing other random drivers behaving aggressively. The predictor variable of acceptance, which was measured by an individual's acceptability in a four-point scale ranging from never to always, captures similar characteristics as does an accepting attitude towards aggressive behaviors, where a higher score indicated high acceptability. Acceptance was a substitute for "attitude" in the TRA. Experience with driving aggressively was regarded as the actual behavior performed by the participants, which was in accordance with the "usage behavior" factor described in the TRA. In addition, permissiveness, which was measured by an

individual's permissive attitude by asking "How serious do you think such behavior is a threat to traffic safety" with the responses ranging from very to not at all, captures similar characteristics, as does a permissive attitude towards aggressive behaviors, where a high score indicates more permissiveness. Permissiveness was another substitute for "attitude." Since the predictor variables of acceptance and permissiveness were similar, each of them was analyzed respectively in the Acceptance Models and Permissiveness Models. A modified version of the TRA, shown in Figure 5.1, was proposed to fit the available data in this study. In the proposed model, perception of the extent to which respondents see aggressive behaviors affects their own experience with engaging in an aggressive manner both directly and indirectly through acceptance/permissiveness, which drivers adopt when in an environment that tolerates aggressive behavior.

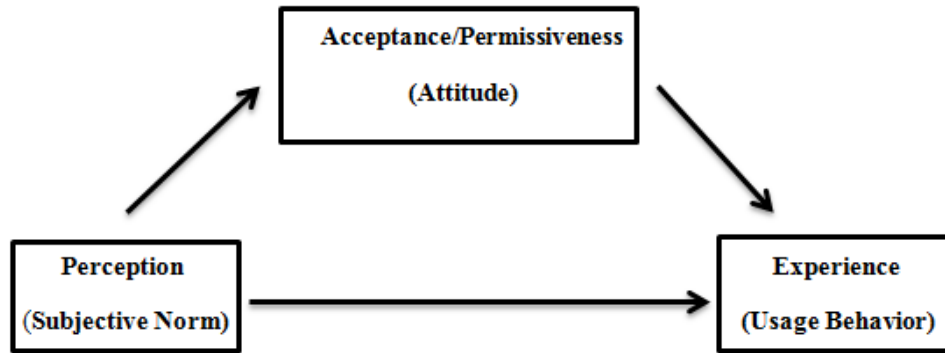

Figure 5.1 The proposed version of the TRA model

Specifically, hypotheses based on the proposed version of TRA were developed to indicate mediating effects of acceptance/permissiveness of experience as:

Hypothesis $\eta 1$: an enhanced perception of aggressive driving behaviors would increase the experience with these behaviors (perception \rightarrow experience);

Hypothesis η_2 : an enhanced perception of aggressive driving behaviors would increase the acceptance/permissiveness towards these behaviors (perception \rightarrow acceptance/permissiveness);

Hypothesis η_3 : an enhanced acceptance/permissiveness of aggressive driving behaviors would increase the experience with these behaviors (acceptance/permissiveness \rightarrow experience).

For the estimation of the path parameters, path analysis, which is a special case of SEM used to assess the fits of theoretical models by biological, behavioral, and social scientists (Featherman & Duncan, 1972), was used to gain insights into the relationships among perception, acceptance/permissiveness, and experience. In this case, latent variables were also the observed variables and there were no attempts to adjust for measurement error. To perform path analysis, an advanced analytical tool in SAS (PROC CALIS) was used. During the PROC CALIS estimation procedure, the maximum likelihood (ML) method was applied to obtain estimates of the strength of relationships, and the results were expressed in standardized terms for their simplicity of interpretation when the metrics of the items were not well understood. Furthermore, since the number of observations in this study was more than 1,000 and the missing cases were less than 8%, no adjustments were made for the missing cases (listwise deletion was used in the data measurement process).

Three steps were involved in the construction process. In the first step, each individual behavior (DWA, speeding, and RLR) was estimated by univariate behavior models, separately. Next, the interactions and relations between any two of the three

behaviors were analyzed in three pairs (DWA and speeding, DWA and RLR, speeding and RLR) in bivariate behavior models. In the final step, perceptions of the frequency of the behavior, expressions of acceptance/permissiveness, and the reported personal experience with all three behaviors were included in trivariate behavior models to examine the relationship among these behaviors. For all of the behavior models (univariate, bivariate, and trivariate), gender differences were considered. After that, demographic and traveling factors such as gender, age, and VMT were added to the trivariate behavior models to explore the differences among demographic groups in aggressive driving behaviors. In particular, as acceptance and permissiveness are similar indicators, they were analyzed in respective model. The detailed process is presented in the following subsections. For each conceptual model, the proposed structure was presented first, followed by the SEM estimates of the path coefficients.

5.3.1 Univariate behavior models

The relations among perception, acceptance/permissiveness, and experience for each individual behavior of DWA, RLR, and speeding were analyzed first to examine the decomposition of the total effects of each behavior. The parameter coefficients were estimated by path analysis, and the estimated results with t-statistics, illustrating the decomposition of total effects for each aggressive behavior, are presented in Figures 5.2 and 5.4.

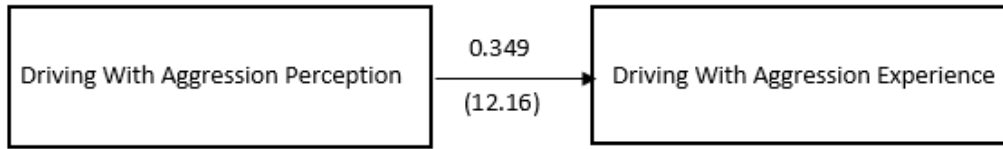

Figure 5.2 The total effects for DWA: Total Effects [0.349 (t=12.16)] = Direct [0.349 (t=12.16)] + Indirect (0)

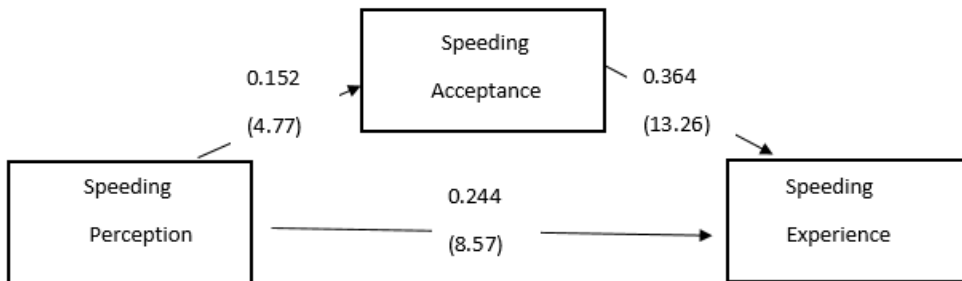

Figure 5.3 The total effects for speeding: Total Effects [0.299 (t=10.07)] = Direct [0.244 (t=8.57)] + Indirect [0.055 (t=4.50)]

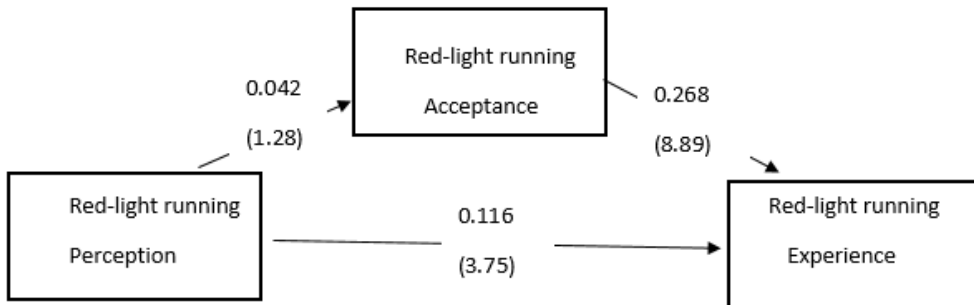

Figure 5.4 The total effects for RLR: Total Effects [0.127 (t=3.97)] = Direct [0.116 (t=3.75)] + Indirect [0.011 (t=1.26)]

By developing univariate behavior models based on the proposed TRA, the decomposition of effects for each of the three aggressive driving behaviors was examined individually. The total effects consisted of a direct effect of perception of experience, and an indirect effect of acceptance on experience, where acceptance was a mediator. The significance of paths was determined by comparing the t-values with the

critical t-statistic ($t^*=2.0$), which was obtained from the corresponding degree of freedom (a large sample size over 1000) and level of significance ($\alpha=0.05$ or 95% confidence level). A t-value higher than the critical t-statistic indicates the statistical significance of the path. For instance, in Fig. 5.2, the direct effect of DWA Perception of DWA Experience had a t-value of 12.16, which was greater than 2.0, indicating a significant direct effect of DWA Perception. Similarly, the perceptions of speeding and RLR also showed significant direct effects on the experience with these behaviors. Because the acceptance of DWA was not available, the indirect effect was not examined for DWA. Specifically, the t-value for the indirect effect of speeding Acceptance ($t=4.50$) was higher than the critical value ($t^*=2.0$); the indirect effects mediating from speeding Acceptance was significant (as shown in Fig. 5.3). However, the indirect effects of RLR Acceptance ($t=1.26$) were not significant at the analytical level (as shown in Fig. 5.4). Therefore, RLR Acceptance was not mediating for RLR Experience. It can be concluded that the effect of perception on experience was significantly mediated through the acceptance only for speeding behavior.

Recall the literature review in Chapter 2 (Wilson, 1990; Wilde, 1994; Retting et al., 1999; Papadakaki et al., 2008) proposed gender differences in aggressive driving behaviors; descriptive statistics of the indicators in male and female samples from this study is presented in Table 5-3, respectively. As shown in the table, differences are observed between the male and female samples with respect to the variables' means, standard deviations, and extreme values in males and females. The observed mean scores of all the variables for males were higher than for females, which suggests that males are

more aggressive than females based on the identification of the scores. In addition, the pooled t-test also showed significant differences between the two samples ($t > t^* = 2.0$).

Table 5-3: Descriptive Statistics of Variables for Males and Females

Variable	Male			Female			Pooled t-test
	N	Mean (S.D.)	Min/Max	N	Mean (S.D.)	Min/Max	
APer	454	3.33 (0.93)	1/5	630	3.01 (0.91)	1/5	5.61
AExp	438	1.04 (0.98)	0/4	598	0.85 (0.87)	0/4	3.29
SPer	453	3.62 (0.85)	1/5	627	3.22 (0.94)	1/5	7.11
SAcc	455	1.84 (0.69)	1/4	631	1.61 (0.61)	1/3.67	5.74
SExp	436	1.44 (1.11)	0/5	592	1.04 (0.96)	0/5	6.19
RPer	453	2.80 (1.04)	1/5	624	2.47 (0.93)	1/5	5.46
RAcc	455	1.32 (0.48)	1/3.33	633	1.27 (0.43)	1/3.67	1.98
RExp	439	0.82 (0.80)	0/4	596	0.66 (0.70)	0/4	3.36

Table 5-4: Decomposition of Total Effects (t-statistics) for Males and Females

Gender	Male			Female		
	Total	Direct	Indirect	Total	Direct	Indirect
Effects/Behavior						
Driving with Aggression (DWA)	0.346 (8.13)	0.346 (8.13)	0	0.325 (8.71)	0.325 (8.71)	0
Speeding	0.263 (5.84)	0.222 (5.23)	0.041 (2.23)	0.301 (7.95)	0.245 (6.63)	0.056 (3.84)
Red-light Running (RLR)	0.108 (2.26)	0.092 (1.99)	0.016 (1.21)	0.119 (2.89)	0.120 (3.00)	-0.001 (-0.11)

After examining the differences in descriptive statistics, the decomposition of the total effects for univariate behavior models were also analyzed for the different genders, and the results are presented in Table 5-4. There is little difference observed from the table. However, it was found that the indirect effect of RLR Perception of RLR Experience was negative for female participants, which indicates that a female's enhanced perception of RLR decreased her frequency of running a red light, through her

RLR acceptance. In addition, the path coefficients (t-statistics) considering gender differences are presented in Appendix B, Figures B.1 and B.2.

Since gender was the most dichotomous predictor variable compared to other demographic variables such as age and VMT in this dataset, the population in this study was only divided by male and female samples. The categories and intervals of age and VMT might vary depending on a different survey questionnaire design, so the split samples for these two variables were not included.

5.3.2 Bivariate behavior models

After analyzing the relationships of perception, acceptance/permissiveness attitude, and experience for each individual behavior, we were motivated to investigate the associations between two behaviors. To achieve this, the interactions and relations between each two of three behaviors were examined through fully-recursive mediating models for three pairs: DWA and speeding, DWA and RLR, and RLR and speeding. The estimated coefficients (t-statistics) for three pairs are presented in Figures 5.5 and 5.7. The decomposition of total effects is also presented in Table 5.5.

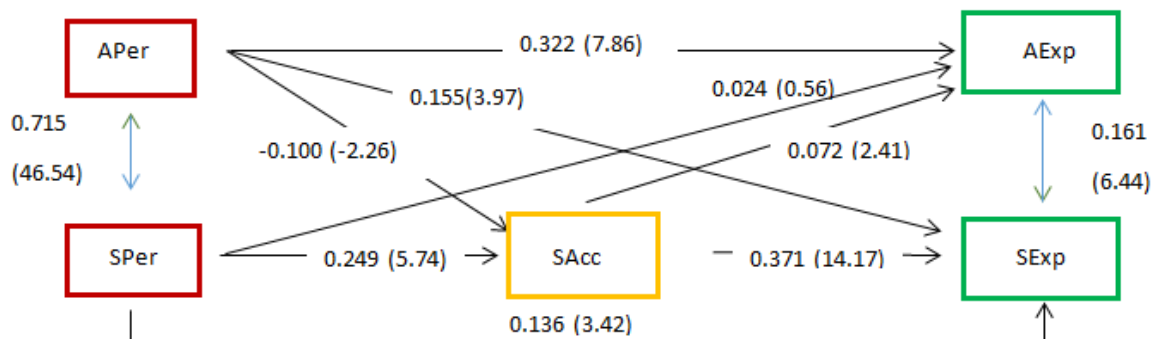

Figure 5.5 Theoretical model of proposed relationships between perception, acceptance, and experience with DWA and speeding. $N=1016$, $\chi^2_0 = 0$, $RMSR=0$, $AGFI= 1$, $CFI= 1$.

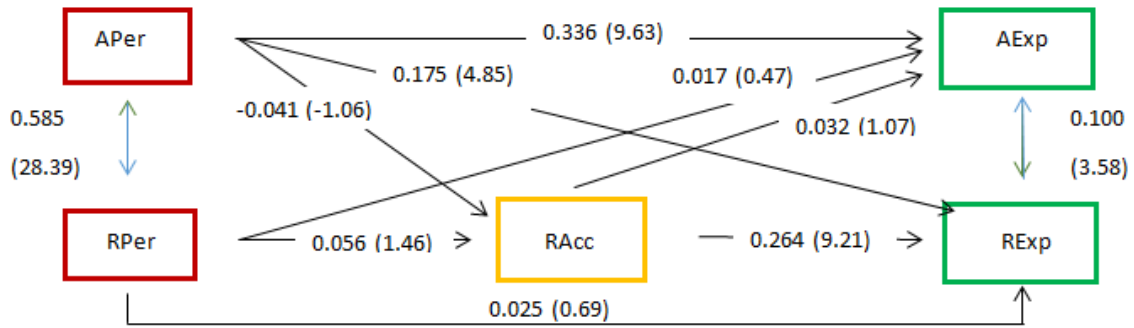

Figure 5.6 Theoretical model of proposed relationships between perception, acceptance, and experience with DWA and RLR. N=1022, $\chi^2_0 = 0$, RMSR=0, AGFI= 1, CFI= 1.

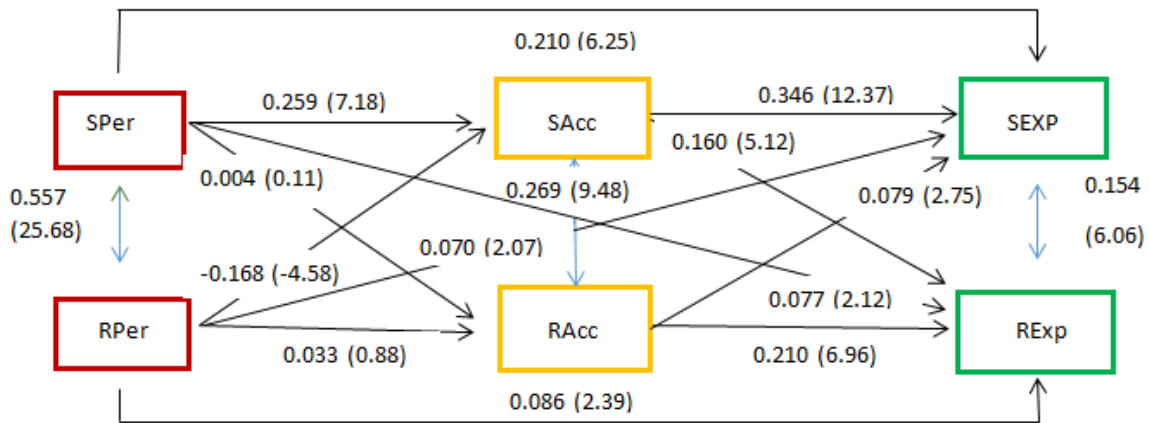

Figure 5.7 Theoretical model of proposed relationships between perception, acceptance, and experience with speeding and RLR. N=1014, $\chi^2_0 = 0$, RMSR = 0, AGFI = 1, CFI = 1.

Using the same approach by comparing the t-value with the critical t-statistic ($t^*=2.0$), speeding Acceptance, which was significantly predicted by speeding Perception at a significance level of 0.05 ($t=5.47$ is greater than $t^*=2.0$), and also had significant positive impacts on DWA Experience ($t=2.41$) and RLR Experience ($t=5.12$), as shown in Figures 5.5 and 5.7. However, it was found that RLR Acceptance was not significantly predicted by DWA Perception ($t= -1.06$) or speeding Perception ($t=0.11$),

and its effect on DWA Experience ($t=1.07$) was insignificant, as shown in Figures 5.6 and 5.7.

Table 5-5: Decomposition of the Effects for Bivariate Behavior Models

	From	Total	Direct	Indirect	To
AS Pair	APer	0.3153 (7.68)	0.3225 (7.86)	-0.0072 (-1.65)	AExp
		0.1184 (2.80)	0.1553 (3.97)	-0.0369 (-2.23)	SExp
	SPer	0.0417 (0.99)	0.0238 (0.56)	0.0179 (2.22)	AExp
		0.2279 (5.44)	0.1355 (3.42)	0.0924 (5.29)	SExp
AR Pair	APer	0.3342 (9.59)	0.3355 (9.63)	-0.0013 (-0.75)	AExp
		0.1646 (4.39)	0.1753 (4.85)	-0.0107 (-1.05)	RExp
		0.0187 (0.52)	0.017 (0.47)	0.00176 (0.86)	AExp
	RPer	0.0399 (1.05)	0.0251 (0.69)	0.0148 (1.44)	RExp
		0.3002 (8.62)	0.2104 (6.25)	0.0898 (5.82)	SExp
		0.1196 (3.22)	0.0774 (2.12)	0.0422 (3.08)	RExp
SR Pair	SPer	0.0142 (0.39)	0.0695 (2.07)	-0.0553 (-3.74)	SExp
		0.0662 (1.78)	0.086 (2.39)	-0.0197 (-1.58)	RExp

The decomposed effects of the three pairs, as shown in Table 5-5, indicates that acceptance of speeding is a mediator for DWA/RLR Experience, with the positively significant indirect effects ($t=2.22$ for DWA and $t=3.08$ for RLR). Therefore, the models were mediated that the perceptions of speeding could affect experience with RLR both

directly and indirectly through acceptance, with the same results found for RLR Perception of speeding Experience ($t = -3.74$). It is also shown that enhanced perception of DWA decreased the acceptance of speeding and RLR. Thus, the negative indirect effects through acceptance reduced the total effects from DWA Perception of speeding/RLR Experience and direct effects were slightly larger than the total effects. The negative indirect effects were insignificant so that the total effects were only slightly influenced.

The path coefficients (t-statistics) considering gender differences are presented in Appendix Figures B.3 to B.8. The results in male and female samples were similar to the results drawn from the entire population. As illustrated earlier, a permissiveness attitude towards each behavior expressed a similar idea as acceptance and was also estimated by the decomposition of effects. Since its predictions were not as strong as those from acceptance, the results are not presented this section. These results are found in the Appendix B, Figure B.9.

5.3.3 Trivariate behavior models

In sections 5.3.1 and 5.3.2, we first constructed mediating models for univariate behavior with acceptance as a mediator, followed by the interactions between each two behaviors in the bivariate models using the same mediating structure. The results from the univariate behavior and bivariate behavior mediating models showed that perceptions could affect experience both directly and indirectly through acceptance (or permissiveness). Next, we were driven to explore the interactions and relations of all the three behaviors. Based on the preliminary estimation of univariate and bivariate behavior

models, the trivariate behavior models could follow the same construction of the path analysis for an integration of DWA, RLR, and speeding behaviors. To examine the gender differences, the trivariate behavior models for the entire sample and female/male population were analyzed separately. After that, several other demographic characteristics (age and gender), as well as travel information such as VMT, were added to the trivariate behavior models to investigate the differences among demographic groups in aggressive driving behaviors. The results of this detailed analysis are presented in the following subsections.

5.3.3.1. Entire sample

All participants were considered in this analysis to explore their perceptions, acceptance/permissiveness, and their own driving experience with the aggressive driving behaviors. The logical paths were based on the mediating model structure discussed earlier. Similar predictor variables of Acceptance and Permissiveness were estimated separately in each case with the remainder of the structure staying the same, to investigate the similarities and differences between the two variables. The estimated results are presented in the following sections.

Acceptance Model. The proposed structure of the Acceptance Model is shown in Figure 5.8 and the estimation of standardized results is presented in Table 5-6. There were two dimensions observed in the model structure. In the horizontal dimension, for instance, the upper row including RLR Perception, RLR Acceptance, and RLR Experience were shown as the subject regarding the “behavior of RLR”. In the vertical dimension, for example, the first column, including RLR Perception and speeding

Perception, implied a commonality on the concept of “perception.” Since we were also motivated to examine the effects of RLR and speeding on each other (a dyadic effect), including cross-paths and correlating residuals between speeding and RLR represented an attempt to determine whether RLR has a greater or lesser effect on speeding.

Because the perceptions of RLR and speeding had common causes and the unexplained variance from two variables was correlated, the residuals were set to be correlated with each other correlated, as explained in vertical dimension portion above. It is assumed that one’s perception of RLR also affects his/her perceptions of speeding. Apart from the common variance associated with APer, part of SPer residual was also explained by RPer.

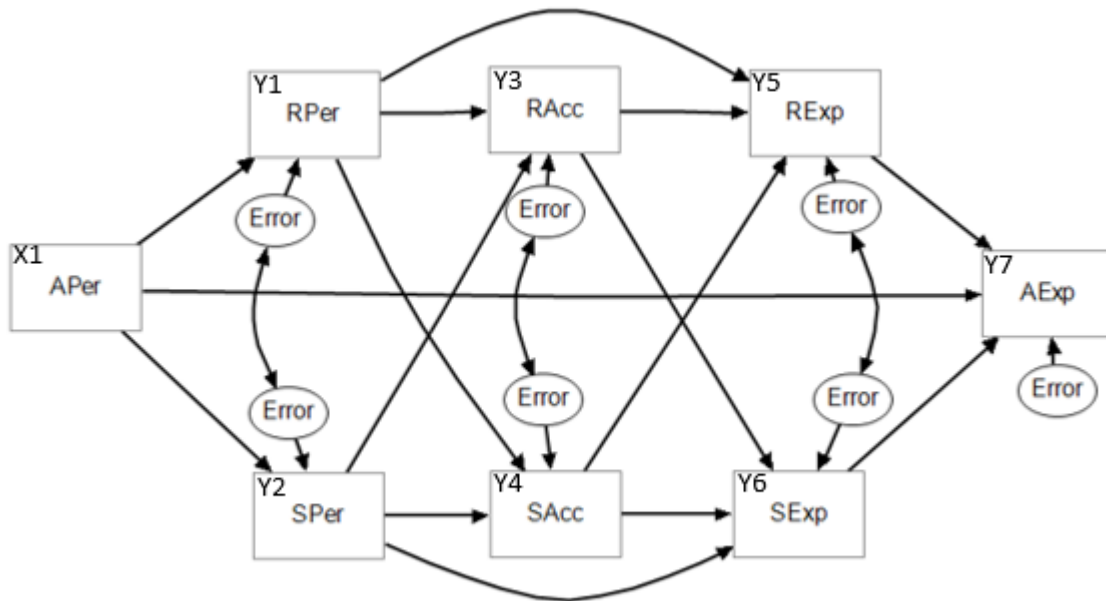

Figure 5.8 Conceptual model of the proposed relationships between perception, acceptance, and experience with respect to each aggressive driving behavior of DWA, RLR, and speeding

$$\text{Eq 1: } RPer = \beta_{61} * APer + \varepsilon$$

$$\text{Eq 2: } SPer = \beta_{31} * APer + \varepsilon$$

$$\text{Eq 3: } RAcc = \beta_{76} * RPer + \beta_{73} * SPer + \varepsilon$$

$$\text{Eq 4: } SAcc = \beta_{43} * SPer + \beta_{46} * RPer + \varepsilon$$

$$\text{Eq 5: } RExp = \beta_{86} * RPer + \beta_{87} * RAcc + \beta_{84} * SAcc + \varepsilon$$

$$\text{Eq 6: } SExp = \beta_{53} * SPer + \beta_{54} * SAcc + \beta_{57} * RAcc + \varepsilon$$

$$\text{Eq 7: } AExp = \beta_{151} * APer + \beta_{158} * RExp + \beta_{155} * SExp + \varepsilon$$

Table 5-6: Standardized Results for Path Coefficient (t-statistics) in Acceptance Model

Variable	Eq.1	Eq.2	Eq.3	Eq.4	Eq.5	Eq.6	Eq. 7
Response	Y ₁ : RPer	Y ₂ : SPer	Y ₃ : RAcc	Y ₄ : SAcc	Y ₅ : RExp	Y ₆ : SExp	Y ₇ : AExp
APer	0.587 (28.44)	0.715 (46.31)					0.282 (9.84)
RPer			0.034 (0.89)	-0.167 (-4.56)	0.117 (3.99)		
SPer			0.002 (0.04)	0.266 (7.36)		0.241 (8.86)	
RAcc					0.206 (6.81)	0.086 (2.99)	
SAcc					0.178 (5.83)	0.340 (12.21)	
RExp							0.064 (2.13)
SExp							0.189 (6.24)
R ²	0.3450	0.5106	0.0012	0.0491	0.1089	0.2258	0.1511
Covariances among Errors							
RPer/SPer		0.136 (7.61)					
RAcc/SAcc		0.271 (9.52)					
RExp/SExp		0.151 (5.88)					

According to the minimum criteria for a significant t-statistic ($t^*=2.0$), the results showed that all the paths were significant except for the ones predicting RLR Acceptance. Specifically, t-values of β_{76} for RLR Perception (0.89) and β_{73} for speeding

Perception (0.04) that were smaller than the critical value of 2.00 indicate their effects on RLR Acceptance were positive, but not significant. Therefore, the acceptance of RLR was not predicted by any of the perceptions (DWA, RLR, and speeding). The rest of the effects were all shown to be significant. For instance, the value for β_{61} was 0.587 and the positive sign indicated that the DWA Perception had a positive effect on the RLR perception. A t-value of 28.44 that was much greater than 2.00 indicated a significant effect from DWA Perception. The significant effect meant that an enhanced perception of DWA would provide an increased perception of RLR. In addition, an enhanced perception of RLR resulted in a high acceptance of RLR, but a low acceptance of speeding; the enhanced RLR perception also led to a higher number of reports of experience with RLR, which reflected drivers' actual behavior. On the other hand, an enhanced perception of speeding raised the acceptance of RLR and speeding, as well as triggered one's behavior with both RLR and speeding, shown by a high reported frequency of experience doing these behaviors. Similar effects could also be seen in the acceptance of speeding, where a high acceptance led to a high frequency of RLR and speeding experience. The frequency of DWA experience was significantly increased with one's experience with RLR and speeding. Although the acceptance of RLR was not predicted or explained by any of the indicators, it still had a positive impact on the experience with RLR and speeding.

The acceptance of RLR might be predicted by other factors that were not involved in this study. Recall from the Cronbach's α value (0.4463) for RLR Acceptance during the data measurement process in Chapter 3, it showed a weaker

reliability and association among the items, which made this predictor slightly weaker. Moreover, as seen in the descriptive statistics in Table 5-1, the mean of this predictor (1.29) was close to the left end (0), representing a lower aggressive inclination. The predictor of RLR Acceptance had a very narrow range of standard deviation. The insignificant path may be due to the individual's risk perception of RLR in a real society, which is from one's sub-consciousness that the risk of RLR is very high and the influence of RLR is vital.

As expected, the results from the integrated trivariate behavior models were fairly consistent with the univariate behavior models (Section 5.3.1) and bivariate behavior models (Section 5.3.2), demonstrating that the perceptions of various aggressive behaviors positively affect participants' driving experience, both directly and indirectly, through acceptance. Also, RLR acceptance had less significant impacts.

Permissiveness Model. As noted, Permissiveness expressed a similar concept as Acceptance; a same model structure was estimated, substituting acceptance with permissiveness, to investigate the similarities and differences between the two variables. The proposed structure of the Permissiveness Model is shown in Figure 5.9, and the estimation of the standardized results is presented in Table 5-7.

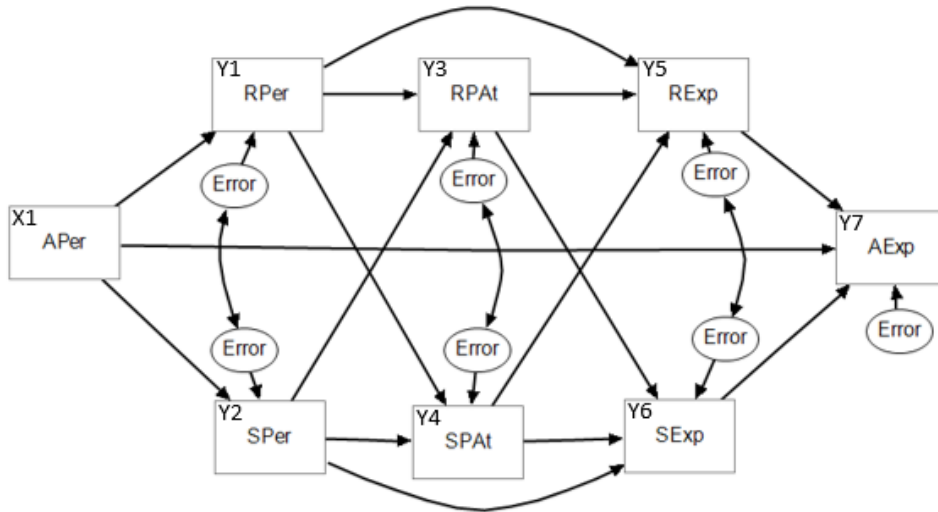

Figure 5.9 Conceptual model of the proposed relationships between perception, permissiveness, and experience with respect to each aggressive driving behavior of DWA, RLR, and speeding

$$\text{Eq 1: } RPer = \beta_{61} * APer + \varepsilon$$

$$\text{Eq 2: } SPer = \beta_{31} * APer + \varepsilon$$

$$\text{Eq 3: } RPAt = \beta_{106} * RPer + \beta_{103} * SPer + \varepsilon$$

$$\text{Eq 4: } SPAt = \beta_{93} * SPer + \beta_{96} * RPer + \varepsilon$$

$$\text{Eq 5: } RExp = \beta_{86} * RPer + \beta_{810} * RPAt + \beta_{89} * SPAt + \varepsilon$$

$$\text{Eq 6: } SExp = \beta_{53} * SPer + \beta_{59} * SPAt + \beta_{510} * RPAt + \varepsilon$$

$$\text{Eq 7: } AExp = \beta_{151} * APer + \beta_{158} * RExp + \beta_{155} * SExp + \varepsilon$$

Although the Permissiveness Model showed fairly similar results as were obtained from the Acceptance Model, there were four noticeable differences: 1) the perception of RLR had a significantly negative impact ($t = -2.85$) on the permissiveness of RLR; 2) the perception of speeding had an insignificantly positive impact ($t = 1.25$) on the permissiveness of speeding; 3) permissiveness of RLR did not have a significant effect ($t = 1.80$) on the experience with RLR; 4) permissiveness of RLR did not have a significant effect ($t = 0.58$) on the experience with speeding. It could be seen that

acceptance and permissiveness measured similar characteristics and captured similar ideas. However, the impacts of permissiveness were slightly weaker compared to acceptance, as shown by the t-statistics.

Table 5-7: Standardized Results for Path Coefficient (t-statistics) in Permissiveness Model

Variable	Eq.1	Eq.2	Eq.3	Eq.4	Eq.5	Eq.6	Eq. 7
Response	Y ₁ : RPer	Y ₂ : SPer	Y ₃ : RPA _t	Y ₄ : SPA _t	Y ₅ : RExp	Y ₆ : SExp	Y ₇ :AExp
APer	0.584 (28.03)	0.716 (46.44)					0.280 (9.78)
RPer			-0.107 (-2.85)	-0.086 (-2.25)	0.132 (4.37)		
SPer			0.052 (1.38)	0.047 (1.25)		0.297 (10.60)	
RPA _t					0.060 (1.80)	0.019 (0.58)	
SPA _t					0.078 (2.34)	0.126 (3.96)	
RExp							0.064 (2.11)
SExp							0.192 (6.33)
R ²	0.3406	0.5120	0.0080	0.0050	0.0282	0.1058	0.1514
Covariances among Errors							
RPer/SPer		0.139 (7.77)					
RPA _t /SPA _t		0.358 (13.07)					
RExp/SExp		0.234 (8.40)					

The results were consistent with the previous analysis results showing that acceptance had a stronger significant effect on experience, and the effect of perception was much stronger on acceptance, rather than on permissiveness. This phenomenon results from the measure of the variables. Recall from Chapter 3, a new index that

combined three items was created for acceptance, which made it a stronger predictor than the permissiveness results that were derived from a single answer.

Table 5-8: Fit Summary for Acceptance and Permissiveness Models

Fit summary/Model	Acceptance	Permissiveness
N Observations	1007	1004
N Variables	8	8
Chi-Square	35.7710	26.1284
Chi-Square DF	10	10
Root Mean Square Residual (RMSR)	0.0220	0.0224
RMSEA Estimate	0.0506	0.0401
Goodness of Fit Index (GFI)	0.9913	0.9936
Adjusted GFI (AGFI)	0.9686	0.9769
Bentler-Bonett NFI	0.9818	0.9853

The fit summary for Acceptance and Permissiveness Models is presented in Table 5-8. Take the Acceptance Model as an example, where a Chi-square value around three times the amount of its degrees of freedom indicated a good fit. A root mean square error of approximation (RMSEA) value of 0.0506 that was smaller than 0.06 at the analytical level, and a root mean square residual (RMSR) value of 0.0220 that was under 0.05 were quite good fits. In addition, a comparative fit index (CFI) value of 0.9913 that was close to 1.0, and an adjusted goodness-of-fit index (AGFI) value of 0.9686 that was greater than 0.95 suggests it was an excellent model. Even though the fit summary indicated that the Permissiveness Model fit better than the Acceptance Model, the Acceptance Model had stronger indications, larger estimated coefficients, and more significant paths, which made it more convincing and accurate than the Permissiveness Model. The primary results of this analysis can be obtained from the Acceptance Model.

5.3.3.2. Gender differences

According to previous studies, gender plays an important role in predicting aggressive driving behaviors, and male drivers tend to be more aggressive than female drivers while driving. Thus, conceptual models were constructed separately for males and females to investigate the differences resulting from gender. All the female respondents (58%) and their answers were selected from the whole population (Q38=2) with respect to each aggressive driving behavior, and the same conceptual structures predicted by the identical paths were constructed for female participants only. Similarly, male respondents (42%) were also separated (Q38=1) and analyzed with the same technique to establish models for male participants alone. The conceptual models for trivariate behavior using both acceptance and permissiveness predictor variables for females and males separately are presented as follows.

Acceptance Model (Female and Male). The proposed structure of the Acceptance Model is shown in Figure 5.8 and the estimation of standardized results for males and females are presented in Figure 5.10.

Compared to the model that represented the entire population, one distinction was observed in Equation 3. It is interesting to see that females had a high acceptance of RLR which resulted from a diminished perception of RLR ($t = -0.36$) and an increased perception of speeding ($t = 0.52$), while results from the males were the opposite; males' high acceptance of RLR came from an increased RLR perception ($t = 1.50$) and a decreased speeding perception ($t = -0.84$). Even though they were not significant at the analysis level, the predictors revealed some gender differences which were unclear in the model predicted with the entire population. In addition, most of the estimated

coefficients showed larger magnitudes for the female population than for males, this may be due to the larger sample size of females.

Permissiveness Model (Female and male). The proposed structure of the Permissiveness Model is shown in Figure 5.9, and the estimation of the standardized results for males and females are presented in Figure 5.11.

Differing from the model in which the whole population was estimated, more significant differences were observed in the Permissiveness Model in Equation 4 and 6. Specifically, in Equation 4, female's high permissiveness towards speeding was explained by an increased speeding perception ($t=1.55$), while male's high permissiveness towards speeding was a result of a decreased speeding perception ($t= -0.94$); in Equation 6, females' high frequency of experience in speeding was derived from low permissiveness towards RLR ($t= -0.09$), while males' was from a high permissiveness towards RLR ($t=1.15$). Apparently, the models predicted more accurate results in the male population, which was more consistent with the models that included all participants.

As the magnitudes of the parameter coefficients did not have clear distinctions, it is difficult to conclude that males are more aggressive in their driving. The overall t-statistics were observed as weaker in males than females at the significance level, possibly due to the smaller male's sample. However, the male population was fairly representative of the general population in this analysis, as the results from male population were consistent with the ones from general population. The gender differences were easy to distinguish.

Figure 5.10 Standardized Results for Path Coefficient (t-statistics) in Acceptance model (Female and Male)

Variable	Eq.1 (F)	Eq.1 (M)	Eq.2 (F)	Eq.2 (M)	Eq.3 (F)	Eq.3 (M)	Eq.4 (F)	Eq.4 (M)	Eq.5 (F)	Eq.5 (M)	Eq.6 (F)	Eq.6 (M)	Eq.7 (F)	Eq.7 (M)
Response	Y ₁	Y ₁	Y ₂	Y ₂	Y ₃	Y ₃	Y ₄	Y ₄	Y ₅	Y ₅	Y ₆	Y ₆	Y ₇	Y ₇
APer	0.543 (18.51)	0.618 (20.68)	0.715 (35.09)	0.696 (27.94)									0.247 (6.48)	0.308 (7.10)
RPer					-0.018 (-0.36)	0.088 (1.50)	-0.184 (-3.94)	-0.173 (-3.00)	0.119 (3.01)	0.100 (2.26)				
SPer					0.025 (0.52)	-0.050 (-0.84)	0.267 (5.79)	0.209 (3.64)			0.243 (6.59)	0.212 (5.13)		
RAcc									0.203 (4.97)	0.217 (4.74)	0.080 (2.05)	0.094 (2.13)		
SAcc									0.126 (3.04)	0.214 (4.67)	0.303 (7.98)	0.354 (8.43)		
RExp													0.066 (1.68)	0.077 (1.61)
SExp													0.237 (6.13)	0.123 (2.55)
R ²	0.29 54	0.3819	0.5110	0.4846	0.0005	0.0052	0.0543	0.0318	0.0839	0.125 9	0.197 0	0.2123	0.1532	0.1386
Covariances among Errors		Female				Male								
RPer/SPer		0.129 (5.28)				0.148 (5.39)								
RAcc/SAcc		0.277 (7.40)				0.257 (5.81)								
RExp/SExp		0.079 (2.23)				0.222 (5.79)								

Figure 5.11: Standardized Results for Path Coefficient (t-statistics) in Permissiveness Model (Female and Male)

Variable	Eq.1 (F)	Eq.1 (M)	Eq.2 (F)	Eq.2 (M)	Eq.3 (F)	Eq.3 (M)	Eq.4 (F)	Eq.4 (M)	Eq.5 (F)	Eq.5 (M)	Eq.6 (F)	Eq.6 (M)	Eq.7 (F)	Eq.7 (M)
Response	Y ₁	Y ₁	Y ₂	Y ₂	Y ₃	Y ₃	Y ₄	Y ₄	Y ₅	Y ₅	Y ₆	Y ₆	Y ₇	Y ₇
APer	0.537 (18.10)	0.618 (20.60)	0.717 (35.39)	0.695 (27.77)									0.247 (6.46)	0.306 (7.02)
RPer					-0.104 (-2.16)	-0.106 (-1.80)	-0.124 (-2.57)	-0.059 (-0.99)	0.122 (3.00)	0.121 (2.64)				
SPer					0.075 (1.54)	0.009 (0.15)	0.075 (1.55)	-0.055 (-0.94)			0.297 (7.93)	0.252 (5.77)		
RPA _t									0.034 (0.77)	0.093 (1.82)	-0.004 (-0.09)	0.057 (1.15)		
SPA _t									0.090 (2.03)	0.039 (0.75)	0.118 (2.78)	0.089 (1.76)		
RE _{exp}													0.063 (1.62)	0.078 (1.63)
SE _{exp}													0.243 (6.27)	0.123 (2.58)
R ²	0.38 13	0.2884	0.5141	0.4834	0.0084	0.0102	0.0113	0.0102	0.0240	0.0244	0.1025	0.0727	0.1562	0.1372
Covariances among Errors	Female				Male									
RPer/SPer			0.136 (5.54)											0.148 (5.42)
RPA _t /SPA _t			0.361 (10.04)											0.353 (8.36)
RE _{exp} /SE _{exp}			0.141 (3.67)											0.346 (8.39)

Table 5-9: Fit Summary for Acceptance and Permissiveness Models with Gender Differences

Fit summary/Model	Acceptance		Permissiveness	
	Female	Male	Female	Male
Gender				
N Observations	577	429	576	427
N Variables	8	8	8	8
Chi-Square	38.1044	12.4424	29.3246	10.9839
Chi-Square DF	10	10	10	10
Root Mean Square Residual (RMSR)	0.0240	0.0192	0.0235	0.0200
RMSEA Estimate	0.0699	0.0239	0.0580	0.0152
Goodness of Fit Index (GFI)	0.9841	0.9928	0.9876	0.9936
Adjusted GFI (AGFI)	0.9427	0.9742	0.9555	0.9770
Bentler-Bonett NFI	0.9637	0.9852	0.9696	0.9856

The fit summary for Acceptance and Permissiveness Models considering gender differences is presented in Table 5-9. In both cases, the models indicated obvious gender differences. The Permissiveness Model provided better predictions for the male population and showed a better fit; in fact, the results were significant. Furthermore, the Acceptance Model demonstrated stronger parameters and significant paths, the results were also important.

5.3.3.3. Demographic models

Apart from gender, other demographic and socioeconomic factors also have some impact on the predictions of the models, as discussed in Chapter 2. According to the literature (Wilson, 1990; Clarke et al., 2002; Retting et al., 1999; Deery, 1999&2013; Letirand and Delhomme, 2005; Hanna et al., 2013; Harbeck and Glendon, 2013; Hutchens et al., 2008; Machin and Kim, 2008), younger populations are estimated to be more aggressive in their driving than older populations; the age factor was included in the trivariate behavior conceptual model to analyze the influence of age on perception of,

acceptance/permissiveness of, and experience with various aggressive driving behaviors. It is noted that an individual's perception, acceptance/permissiveness, and experience also depends largely on one's traveling habits and history. If one drives more miles, he/she has enhanced perceptions and becomes more tolerant, therefore the more experience he/she has had. Thus, VMT is also an important predictor will be analyzed in this study. Again, models were constructed for acceptance and permissiveness separately.

Acceptance Model. The proposed structure of the Acceptance Demographic Model is shown in Figure 5.12 and the estimation of the standardized results is presented in Table 5-10.

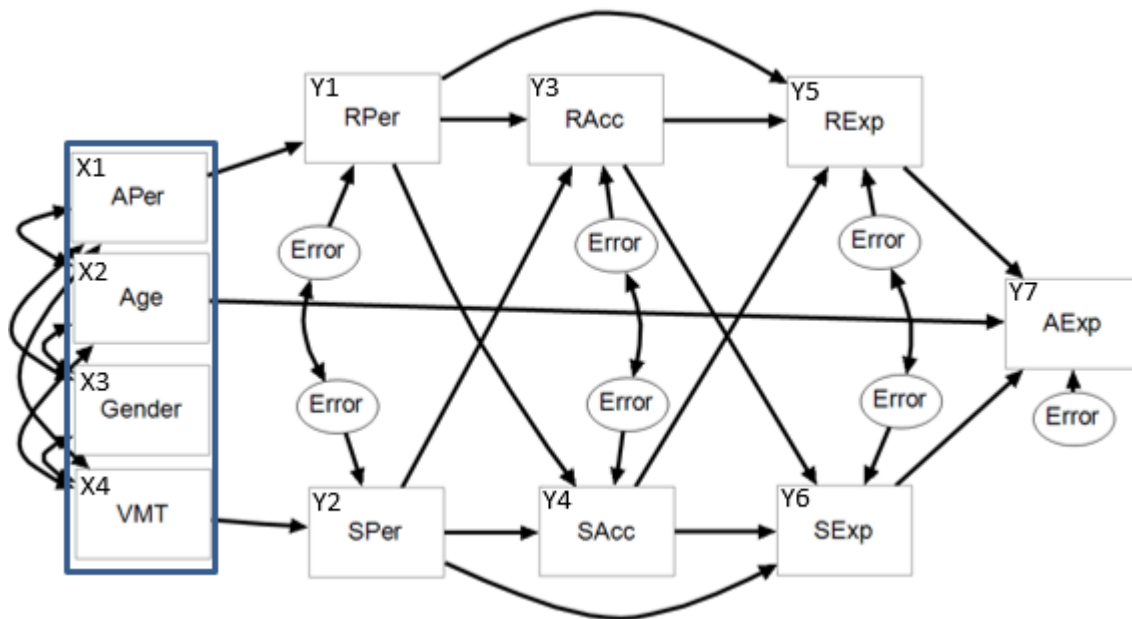

Figure 5.12 Conceptual model of the proposed relationships between perception, acceptance, and experience with respect to each aggressive driving behavior of DWA, RLR, and speeding, taking demographic predictor variables (age, gender, and VMT) into consideration

$$\text{Eq 1: } RPer = \beta_{61} * APer + \beta_{612} * Age + \beta_{614} * Gender + \beta_{613} * VMT + \varepsilon$$

$$\text{Eq 2: } SPer = \beta_{31} * APer + \beta_{312} * Age + \beta_{314} * Gender + \beta_{313} * VMT + \varepsilon$$

$$\text{Eq 3: RAcc} = \beta_{76} * \text{RPer} + \beta_{73} * \text{SPer} + \beta_{71} * \text{APer} + \beta_{712} * \text{Age} + \beta_{714} * \text{Gender} + \beta_{713} * \text{VMT} + \varepsilon$$

$$\text{Eq 4: SAcc} = \beta_{43} * \text{SPer} + \beta_{46} * \text{RPer} + \beta_{41} * \text{APer} + \beta_{412} * \text{Age} + \beta_{414} * \text{Gender} + \beta_{413} * \text{VMT} + \varepsilon$$

$$\text{Eq 5: RExp} = \beta_{86} * \text{RPer} + \beta_{87} * \text{RAcc} + \beta_{84} * \text{SAcc} + \beta_{81} * \text{APer} + \beta_{812} * \text{Age} + \beta_{814} * \text{Gender} + \beta_{813} * \text{VMT} + \varepsilon$$

$$\text{Eq 6: SExp} = \beta_{53} * \text{SPer} + \beta_{54} * \text{SAcc} + \beta_{57} * \text{RAcc} + \beta_{51} * \text{APer} + \beta_{512} * \text{Age} + \beta_{514} * \text{Gender} + \beta_{513} * \text{VMT} + \varepsilon$$

$$\text{Eq 7: AExp} = \beta_{151} * \text{APer} + \beta_{1512} * \text{Age} + \beta_{1514} * \text{Gender} + \beta_{1513} * \text{VMT} + \beta_{158} * \text{RExp} + \beta_{155} * \text{SExp} + \varepsilon$$

With the addition of more exogenous variables in the proposed demographic model, the paths from perception of DWA to acceptance of RLR/speeding became insignificant. This result is reasonable since the acceptance of RLR was not predicted by any of the variables, as discussed before.

Except for the perception of RLR ($t=4.18$) and DWA experience ($t=0.57$), age had negative impacts on all the remaining variables. Since the age factor was in an ascending order, where high scores indicated older groups, negative effects illustrated that the younger the participants were, the enhanced perceptions, high acceptance, and more experience they had in various aggressive driving behaviors. The enhanced perceptions of RLR for older people could be explained by that the fact that they have spent more of their lives driving, so they have perceived more driving behaviors and become more sensitive to these behaviors. Though the effect of age on the perception of speeding ($t= -0.37$) was not significant at a 95% confidence interval, it still captured the negative relationship between age and aggressive behavior.

Table 5-10: Standardized Results for Path Coefficient (t-statistics) in Demographic Acceptance Model

Variable	Eq.1	Eq.2	Eq.3	Eq.4	Eq.5	Eq.6	Eq. 7
Response	Y ₁ : RPer	Y ₂ : SPer	Y ₃ : RAcc	Y ₄ : SAcc	Y ₅ : RExp	Y ₆ : SExp	Y ₇ : AExp
APer	0.604 (26.60)	0.688 (38.06)	-0.081 (-1.64)	-0.085 (-1.80)	0.118 (3.05)	0.100 (2.51)	0.268 (8.66)
Age	0.112 (4.18)	-0.009 (-0.37)	-0.089 (-2.66)	-0.155 (-4.88)	-0.097 (-3.08)	-0.155 (-5.41)	0.018 (0.57)
Gender	-0.095 (-3.50)	-0.068 (-2.92)	-0.063 (-1.86)	-0.134 (-4.17)	-0.034 (-1.08)	-0.071 (-2.43)	-0.015 (-0.49)
VMT	-0.034 (-1.22)	0.077 (3.28)	-0.022 (-0.63)	0.037 (1.14)	0.021 (0.65)	0.071 (2.44)	0.033 (1.05)
RPer			0.058 (1.43)	-0.154 (-3.98)	0.038 (1.04)		
SPer			0.023 (0.48)	0.260 (5.79)		0.122 (3.09)	
RAcc					0.031 (6.72)	0.028 (2.53)	
SAcc					0.150 (4.72)	0.307 (10.79)	
RExp							0.061 (1.98)
SExp							0.186 (5.73)
R ²	0.3556	0.5277	0.0135	0.1009	0.1400	0.2785	0.1575
Covariances among Exogenous Variables							
APer/Age			-0.284 (-9.66)				
APer/Gender			-0.154 (-4.92)				
Age/Gender			0.063 (1.97)				
APer/VMT			0.213 (6.98)				
Age/VMT			-0.124 (-3.94)				
Gender/VMT			-0.318 (-11.06)				
Covariances among Errors							
RPer/SPer			0.136 (7.71)				
RAcc/SAcc			0.262 (9.32)				
RExp/SExp			0.117 (4.70)				

In accordance with the results presented in the section on gender differences, the gender variable involved in the demographic model also had negative impacts on perceptions of, acceptance of, and experience with various aggressive driving behaviors, including RLR, speeding, and DWA. As males were presented in a lower score, negative effects indicated that males were more aggressive drivers. Compared to the conceptual models that were separately analyzed for males and females, the results from this demographic model indicated a clear trend that male drivers had a higher inclination towards aggressive driving than female drivers.

The effects on VMT were not as strong as expected. VMT had a negative influence on the perception ($t = -1.22$) and acceptance of RLR ($t = -0.63$), and a positive influence on the remaining variables. Because VMT was categorized in an ascending order, it illustrates that the more miles traveled by a participant, the increased perception and acceptance he/she had of speeding, and higher frequency of speeding and RLR experience were involved. The negative impacts of VMT on perception and acceptance of RLR might also be due to the same reason earlier discussed.

All of the paths without demographic variables that predicted the relationship among perceptions, acceptance, and experience were borrowed directly from the trivariate behavior models. After including the demographic variables, the signs of path coefficients from this part of the structure remained the same, with slightly smaller magnitudes. Insignificant effects were found from RLR Perception to RLR Experience and from RLR/speeding Perception to RLR Acceptance, which confirmed the finding that the acceptance of RLR was isolated from the structure, and not predicted by any of

the perceptions (DWA, RLR, and speeding). In addition, even though none of the demographic factors made significant contributions to DWA Experience at the analytical level, they captured the positive/negative relationships between the demographic groups and aggressive driving behaviors.

Permissiveness model. The acceptance variable in the demographic model was replaced by the permissiveness variable as accomplished for the previous model to examine their similarities and to validate the demographic model. The proposed structure of the Permissiveness Demographic Model is shown in Figure 5.13 and the estimation of standardized results is presented in Table 5-11.

Fortunately, most of the results obtained in this model were consistent with the Acceptance Model except for three differences. One difference was that VMT had a positive impact on the permissiveness of RLR ($t=1.73$) rather than a negative impact on the RLR Acceptance ($t= -0.63$) observed in last model. The second difference was that perception of RLR had a negative impact on the permissiveness of RLR ($t= -1.89$). The third and final difference was that perception of speeding had a negative impact on the permissiveness of speeding ($t= -0.22$). Since the permissiveness came from a weak predictor variable, the results were within expectations and considered acceptable.

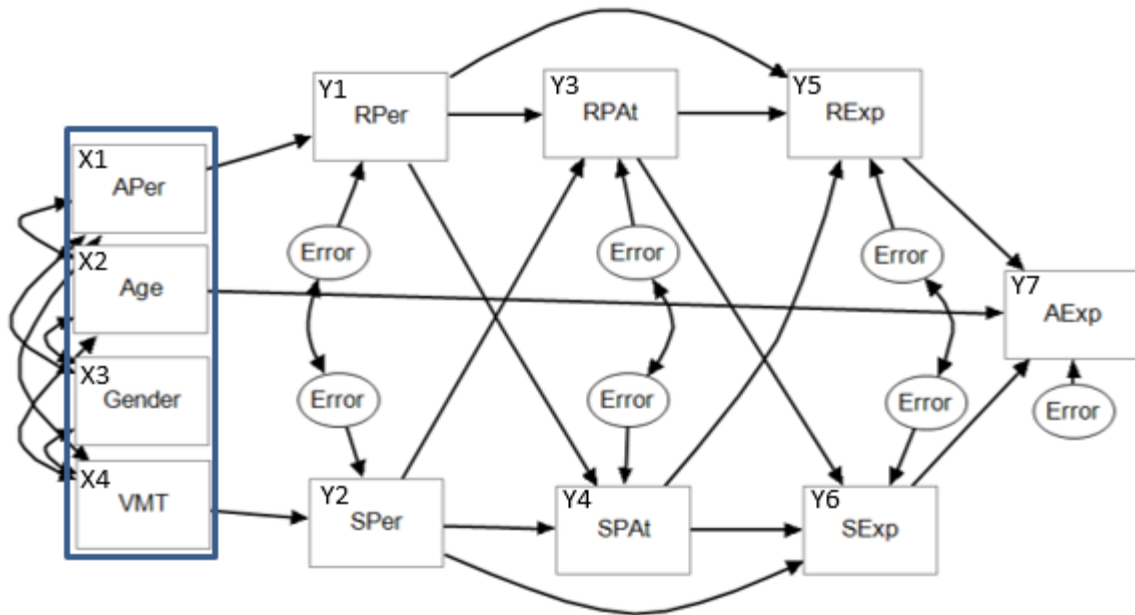

Figure 5.13 Conceptual model of the proposed relationships between perception, permissiveness, and experience with respect to each aggressive driving behavior of DWA, RLR, and speeding, with taking demographic predictor variables (age, gender, and VMT) into consideration

$$\text{Eq 1: } RPer = \beta_{61} * APer + \beta_{612} * Age + \beta_{614} * Gender + \beta_{613} * VMT + \varepsilon$$

$$\text{Eq 2: } SPer = \beta_{31} * APer + \beta_{312} * Age + \beta_{314} * Gender + \beta_{313} * VMT + \varepsilon$$

$$\text{Eq 3: } RPAI = \beta_{106} * RPer + \beta_{103} * SPer + \beta_{101} * APer + \beta_{1012} * Age + \beta_{1014} * Gender + \beta_{1013} * VMT + \varepsilon$$

$$\text{Eq 4: } SPAI = \beta_{93} * SPer + \beta_{96} * RPer + \beta_{91} * APer + \beta_{912} * Age + \beta_{914} * Gender + \beta_{913} * VMT + \varepsilon$$

$$\text{Eq 5: } RExp = \beta_{86} * RPer + \beta_{810} * RPAI + \beta_{89} * SPAI + \beta_{81} * APer + \beta_{812} * Age + \beta_{814} * Gender + \beta_{813} * VMT + \varepsilon$$

$$\text{Eq 6: } SExp = \beta_{53} * SPer + \beta_{59} * SPAI + \beta_{510} * RPAI + \beta_{51} * APer + \beta_{512} * Age + \beta_{514} * Gender + \beta_{513} * VMT + \varepsilon$$

$$\text{Eq 7: } AExp = \beta_{151} * APer + \beta_{1512} * Age + \beta_{1514} * Gender + \beta_{1513} * VMT + \beta_{158} * RExp + \beta_{155} * SExp + \varepsilon$$

Table 5-11: Standardized Results for Path Coefficient (t-statistics) in Demographic Permissiveness Model

Variable	Eq.1	Eq.2	Eq.3	Eq.4	Eq.5	Eq.6	Eq. 7
Response	Y ₁ : RPer	Y ₂ : SPer	Y ₃ : RPA _t	Y ₄ : SPA _t	Y ₅ : RExp	Y ₆ : SExp	Y ₇ :AExp
APer	0.602 (26.38)	0.687 (37.90)	-0.031 (-0.63)	-0.031 (-0.65)	0.113 (2.84)	0.055 (1.32)	0.267 (8.59)
Age	0.114 (4.27)	-0.007 (-0.31)	-0.101 (-3.05)	-0.144 (-4.42)	-0.126 (-3.86)	-0.020 (-6.66)	0.022 (0.68)
Gender	-0.092 (-3.38)	-0.066 (-2.80)	-0.007 (-0.21)	-0.148 (-4.52)	-0.062 (-1.85)	-0.104 (-3.36)	-0.014 (-0.46)
VMT	-0.035 (-1.27)	0.077 (3.24)	0.059 (1.73)	0.078 (2.34)	0.021 (0.64)	0.080 (2.56)	0.032 (1.02)
RPer			-0.075 (-1.89)	-0.089 (-2.19)	0.049 (1.30)		
SPer			0.020 (0.43)	-0.010 (-0.22)		0.193 (4.73)	
RPA _t					0.052 (1.57)	0.008 (0.26)	
SPA _t					0.041 (1.21)	0.064 (2.01)	
RExp							0.062 (2.00)
SExp							0.188 (5.81)
R ²	0.3518	0.5247	0.0217	0.0595	0.0664	0.1796	0.1566
Covariances among Exogenous Variables							
APer/Age			-0.281 (-9.52)				
APer/Gender			-0.155 (-4.95)				
Age/Gender			0.065 (2.02)				
APer/VMT			0.212 (6.92)				
Age/VMT			-0.120 (-3.81)				
Gender/VMT			-0.318 (-11.05)				
Covariances among Errors							
RPer/SPer			0.138 (7.77)				
RPA _t /SPA _t			0.336 (12.31)				
RExp/SExp			0.190 (7.03)				

Overall, the remaining part of the model adopted from trivariate behavior conceptual models was not greatly influenced by the inclusion of demographic exogenous variables. It is confirmed once more that acceptance and permissiveness measure similar characteristics; also, acceptance proved to be a stronger predictor than permissiveness. The results thus provide significant evidence to state that the conceptual models were valid.

Table 5-12: Fit Summary for Demographic Acceptance and Permissiveness Models

Fit summary/Model	Acceptance	Permissiveness
N Observations	979	977
N Variables	11	11
Chi-Square	3.0110	1.1097
Chi-Square DF	6	6
Root Mean Square Residual (RMSR)	0.0039	0.0017
RMSEA Estimate	0.0000	0.0000
Goodness of Fit Index (GFI)	0.9994	0.9998
Adjusted GFI (AGFI)	0.9938	0.9977
Bentler-Bonett NFI	0.9987	0.9995

The fit summary for Acceptance and Permissiveness Models, including demographic factors, is presented in Table 5-12. The two models were similar and the Permissiveness Model fitted slightly better than the Acceptance Model as previously found. However, the Acceptance Model that had stronger predictors and logical significant paths could be considered as the better choice.

In this section, all path models are estimated as a special case of SEM models where the measurement error was not managed. To confirm the conceptual results and validate the SEM analysis, several latent variables related to aggressive driving

behaviors are established and trials of SEM structural models are discussed in the next section.

5.4 Structural Equation Model Testing

The variables discussed in the last section were all measurable (observed). To better understand the latent relationships among various aggressive driving behaviors, we are attempting to treat acceptance and permissiveness items as two indicators of a single latent variable in this section.

A total of five trial models were constructed using SEM analysis with latent variables. Different latent variables were created in each case, with continual modifications being made to adjust the model based on results from each trial. The final resultant model was a compilation of all necessary modifications, and was revealed to provide acceptable results. Specifically, four latent variables were constructed: Perception, Acceptance/Permissiveness of RLR (RA), Acceptance/Permissiveness of Speeding (SA), and Experience with aggressive driving behaviors.

5.4.1 Exploration of five trial models

Using the same idea of mediating effects discussed in Section 5.3 while constructing conceptual models, four latent variables were established in this analysis: 1) Perception: perception of aggressive driving behavior that manifested through DWA perception, speeding perception, and RLR perception; 2) Experience: experience with aggressive driving behavior that manifested through DWA experience, speeding experience, and RLR experience; 3) RA: tolerance of RLR that manifested by

permissiveness towards RLR and RLR acceptance; 4) SA: tolerance of speeding that manifested by permissiveness towards speeding and speeding acceptance.

Model 1: 2A's model. The paths and the structure were analyzed based on the hypotheses proposed earlier in the conceptual models. The proposed structure of 2A's model is shown in Figure 5.14 and the standardized results for path list of 2A's model are presented in Table 5-13.

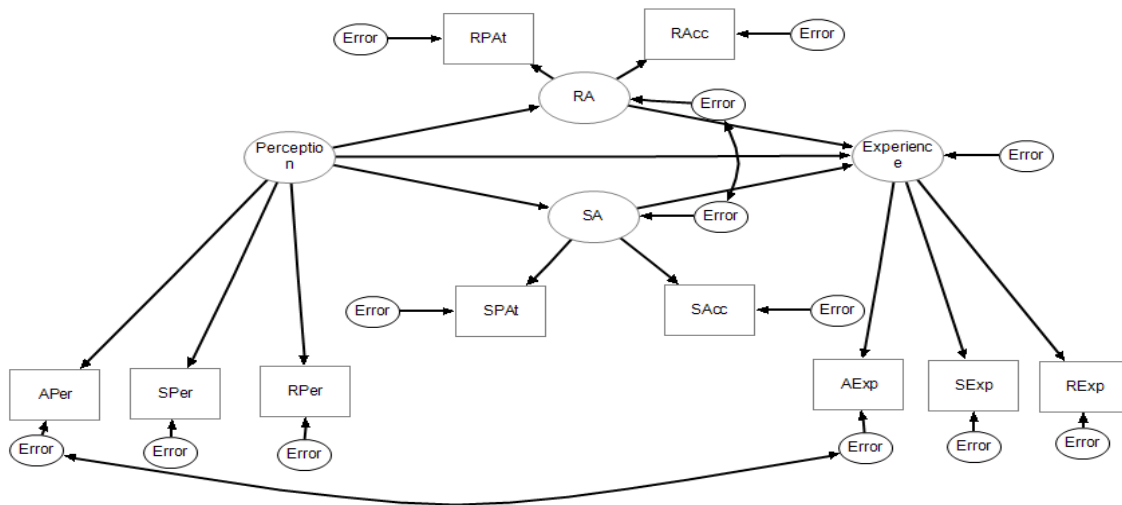

Figure 5.14 A model predicting aggressive driving experience from perception and tolerance of aggressive driving. $N=1002$, $\chi^2_{26} = 229.9751$, $RMSEA=0.0885$, $RMSR=0.0586$, $AGFI= 0.9078$, $CFI= 0.9063$

According to the critical t-statistic ($t^*=2.00$) used in the study, an insignificant effect was found from perception of aggressive driving behaviors to the tolerance of RLR while driving ($t= -0.14$); this means that the first hypothesis was rejected by stating that Tolerance was not predicted by Perception. The paths of Perception to SA ($t=2.69$), RA to Experience ($t=2.25$), and SA to Experience ($t=2.03$) were all shown to be weak, as well as the factor loadings of RA (0.285/0.399) and SA (0.456/0.560), which were both

under 0.6. The correlation of RLR Permissiveness and speeding Permissiveness (1.506) was greater than 1.0, an outcome which was referred to as a Heywood case that the parameter estimates were exceeding their reasonable bounds and causing problems in this model. In addition, the fit of the model was not acceptable ($\chi^2_{26} = 229.9751$, AGFI= 0.9078). Modifications were required and the second trial was performed next.

Table 5-13: Standardized Results for Path List of 2A's Model

Hypothetic Path			Path Coefficient	t-statistics
Experience	<---	Perception	0.487	10.56
RA	<---	Perception	-0.011	-0.14
Experience	<---	RA	0.275	2.25
SA	<---	Perception	0.141	2.69
Experience	<---	SA	0.262	2.03
APer	<---	Perception	0.858	55.08
SPer	<---	Perception	0.832	51.68
RPer	<---	Perception	0.669	32.46
RPAAt	<---	RA	0.285	5.57
RAcc	<---	RA	0.339	5.91
SPAAt	<---	SA	0.456	12.83
SAcc	<---	SA	0.560	14.79
AExp	<---	Experience	0.400	11.71
SExp	<---	Experience	0.698	20.95
RExp	<---	Experience	0.434	12.88
Covariances among Errors				
AExp/APer			0.102	5.05
RPAAt/SPAAt			1.506	6.44

Model 2: Acceptance model. Instead of establishing a latent variable for the tolerance, we attempted to focus on the acceptance of the behaviors. The variables of RLR Acceptance and speeding Acceptance were combined by summing the answers for the two variables and collapsing them into a new observed variable termed Acceptance.

The paths and the structure were analyzed based on the modification, as shown in Figure 5.15. The standardized results for the path list of the Acceptance Model are presented in Table 5-14.

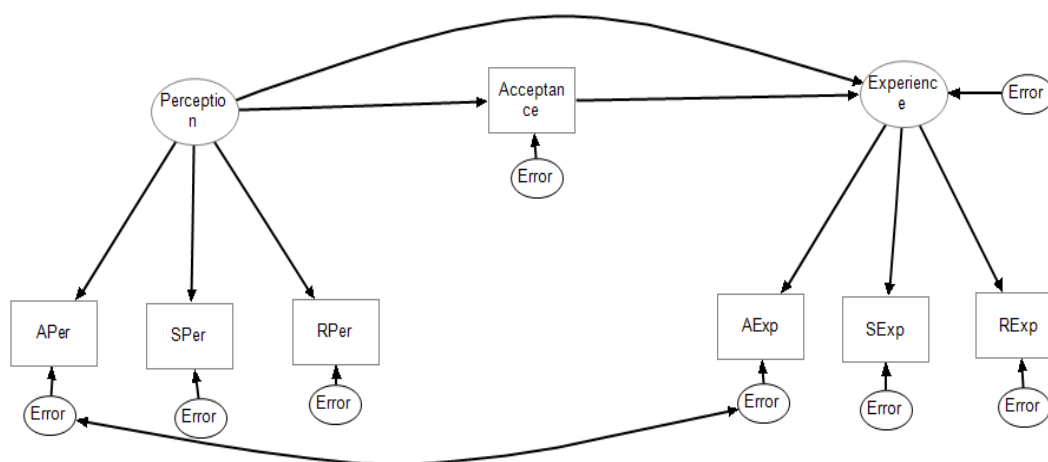

Figure 5.15 Acceptance model predicting aggressive driving experience from perception and acceptance of aggressive driving. $N=1007$, $\chi^2_{11} = 70.1068$, $RMSEA=0.0822$, $RMSR=0.0375$, $AGFI= 0.9520$, $CFI= 0.9674$.

Table 5-14: Standardized Results for Path List of Acceptance Model

Hypothetic Path			Path Coefficient	t-statistics
APer	<---	Perception	0.860	55.26
SPer	<---	Perception	0.828	51.08
RPer	<---	Perception	0.672	32.76
Acceptance	<---	Perception	0.101	2.98
Experience	<---	Perception	0.474	12.75
Experience	<---	Acceptance	0.497	14.36
AExp	<---	Experience	0.385	11.35
SExp	<---	Experience	0.685	21.47
RExp	<---	Experience	0.456	13.92
Covariances among Errors				
AExp/APer			0.102	5.04

In this trial, the impact of the perception of aggressive driving behaviors on the acceptance of speeding and RLR while driving was found to be significant ($t=2.98$). The signs and magnitudes of all the other path coefficients were also acceptable, with a satisfied factor loading for Perception (0.860/0.828/0.672). Although the factor loading for Experience (0.385/0.685/0.456) was slightly weaker, it was still acceptable. The fit of the model had little improvement, but was not yet satisfactory with a large chi-square ($\chi^2_{11} = 70.1068$, AGFI= 0.9520). Along this line, a trial that focused on Permission rather than Acceptance will be tested in the next step.

Model 3: Permission Model. In order to examine the effect of permissiveness on the model prediction, similar measure was performed as for the observed variable of Acceptance. The variables of RLR Permissiveness and speeding Permissiveness were combined and named Permission. The proposed structure with the replacement of permission was analyzed and presented in Figure 5.16, and the standardized results for the path list are presented in Table 5-15.

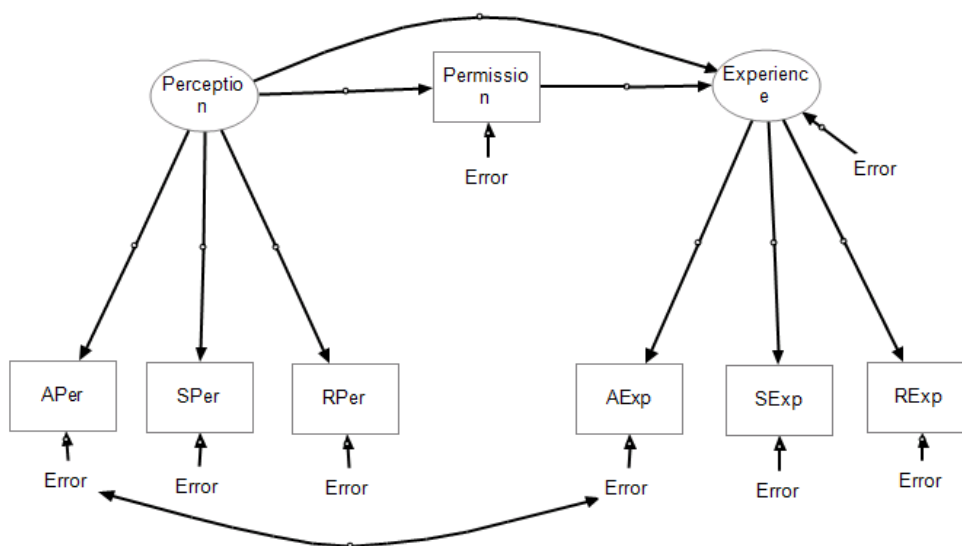

Figure 5.16 Permission model predicting aggressive driving experience from perception and permission of aggressive driving. $N=1004$, $\chi^2_{11} = 31.5537$, $RMSEA=0.0432$, $RMSR=0.0240$, $AGFI= 0.9770$, $CFI= 0.9872$.

Table 5-15: Standardized Results for Path List of Permission Model

Hypothetic Path			Path Coefficient	t-statistics
APer	<---	Perception	0.857	55.01
SPer	<---	Perception	0.834	51.87
RPer	<---	Perception	0.671	32.61
Permission	<---	Perception	-0.024	-0.70
Experience	<---	Perception	0.558	14.28
Experience	<---	Permission	0.183	4.73
AExp	<---	Experience	0.466	12.77
SExp	<---	Experience	0.644	16.92
RExp	<---	Experience	0.420	11.36
Covariances among Errors				
AExp/APer			0.088	4.32

As expected, the path from Perception to Permission was found to be insignificant ($t= -0.70$). No distinctions were observed of the coefficient signs and magnitudes of other paths comparing to the third trial, nor were they observed of the

factor loadings. However, the fit of the model improved greatly ($\chi^2_{11} = 31.5537$, AGFI= 0.9770). The next trial will analyze Acceptance and Permission together.

Model 4: Combined Acceptance and Permission Model. Based on the separate analysis of acceptance and permission, the fourth trial attempted to combine the effects. As shown in Models 3 and 4, the effects of acceptance and permission were opposite, and a simple summation of the four variables was not reasonable. Permission and Acceptance were regarded as two separated observed variables and followed the same logic proposed in last two trials. The effects of both acceptance and permission were included and the structure is presented in Figure 5.17. The standardized results for the path list of the Combined Model are presented in Table 5-16.

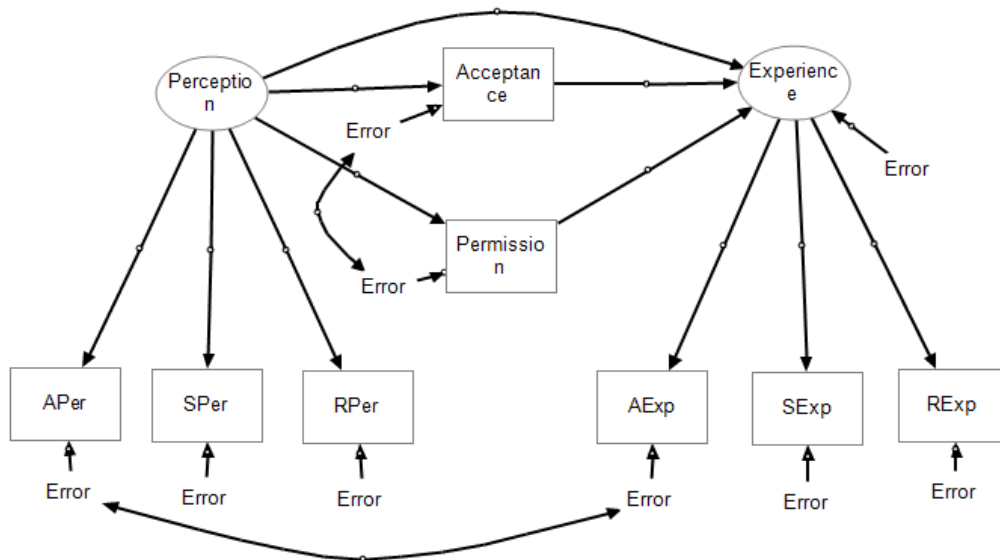

Figure 5.17 Combined model predicting aggressive driving experience from perception, acceptance, and permission of aggressive driving. N=1002, $\chi^2_{11} = 76.8284$, RMSEA=0.0642, RMSR=0.0347, AGFI= 0.9562, CFI= 0.9674.

Table 5-16: Standardized Results for Path List of Combined Model

Hypothetic Path			Path Coefficient	t-statistics
APer	<---	Perception	0.858	55.01
SPer	<---	Perception	0.832	51.55
RPer	<---	Perception	0.670	32.57
Experience	<---	Perception	0.472	12.64
Acceptance	<---	Perception	0.106	3.12
Experience	<---	Acceptance	0.483	13.30
Permission	<---	Perception	-0.024	-0.69
Experience	<---	Permission	0.048	1.30
AExp	<---	Experience	0.386	11.35
SExp	<---	Experience	0.687	21.51
RExp	<---	Experience	0.455	13.87
Covariances among Errors				
AExp/APer			0.106	5.20
Acceptance/ Permissive			0.28	9.96

Again, insignificant impacts were found from Perception to Permission ($t = -0.69$) and from Permission to Experience ($t = 1.30$). The coefficient signs of other paths were the same and their magnitudes were very close to results obtained from the Acceptance Model. The factor loadings and the fit of model were not observed differently from the Acceptance Model. In conclusion, none of the modifications adjusted from trial 2 to trial 4 made significant difference on the model estimation. Other means of data presentation are necessary and will be discussed next section.

Model 5: Permissiveness Model. The last four models were not satisfactory for their fit and factor loadings of the variables. Since the data corresponding to permissiveness attitudes was available for all the three behaviors, it was reasonable to build a parallel structure with three observed variables under each latent variable. On the basis of the first two latent variables, Perception and Experience, established before, a

new latent variable termed PermissiveAt, which was manifested by the permissiveness towards DWA, speeding and RLR, were developed to examine the permissiveness towards aggressive driving behaviors. The same mediating hypotheses were used from the conceptual models presented earlier in this chapter: an enhanced perception of aggressive driving behaviors would increase the experience with aggressive driving behaviors (Perception→Experience), an enhanced perception of aggressive driving behaviors would increase the permissiveness towards aggressive driving behaviors (Perception→PermissiveAt), and higher permissiveness towards aggressive driving behaviors would increase experience with aggressive driving behaviors (PermissiveAt→Experience). According to the hypotheses proposed, the relationship among perception of, permissiveness of, and the experience with each aggressive driving behavior were explored with the structure presented in Figure 5.18. The standardized results for the path list of the Permissiveness Model are presented in Table 5-17.

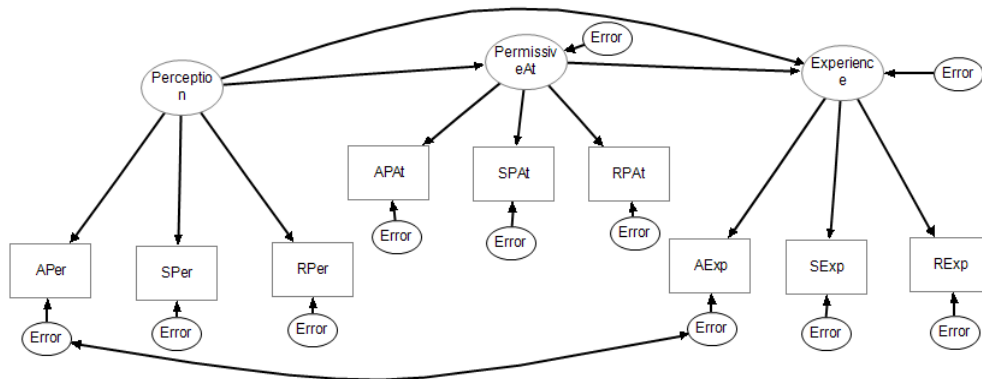

Figure 5.18 Permissiveness model predicting aggressive driving experience from perception and permissiveness towards aggressive driving. $N=1001$, $\chi^2_{11} = 45.3621$, $RMSEA=0.0312$, $RMSR=0.0198$, $AGFI= 0.9806$, $CFI= 0.9885$.

Table 5-17: Standardized Results for Path List of Permissiveness Model

Hypothetic Path			Path Coefficient	t-statistics
APer	<---	Perception	0.856	54.77
SPer	<---	Perception	0.837	52.31
RPer	<---	Perception	0.669	32.45
Experience	<---	Perception	0.556	14.10
PermissiveAt	<---	Perception	-0.016	-0.37
Experience	<---	PermissiveAt	0.284	5.86
APAt	<---	PermissiveAt	0.571	16.07
SPAt	<---	PermissiveAt	0.658	17.82
RPAAt	<---	PermissiveAt	0.541	15.38
AExp	<---	Experience	0.460	12.70
SExp	<---	Experience	0.647	17.28
RExp	<---	Experience	0.426	11.63
Covariances among Errors				
AExp/APer			0.089	4.37

Except for the insignificant effect of Perception of Permissiveness ($t = -0.37$), which was below what was expected, the coefficient signs and magnitudes of all the rest paths were reasonable and significant. The hypotheses were tested to be true that an enhanced perception of aggressive driving behaviors would increase experience with aggressive driving, both directly and indirectly through the permissiveness towards these behaviors. Moreover, the factor loadings for Perception (0.856/0.837/0.669), Permissiveness (0.571/0.658/0.541), and Experience (0.460/0.647/0.426) were satisfactory. The fit summary also indicated a good fit of this model ($\chi^2_{11} = 45.3621$, AGFI= 0.9806). Even though the Permissiveness Model was modified based on the previous models' results and seemed to be acceptable, there was a major limitation of model estimation in the section which will be discussed in the following section.

5.4.2 Model limitation

A significant limitation of constructing all the SEM structural models with latent variables was found in this study. The correlation matrix was not a full rank due to the high inter-correlations among the exogenous predictors; this meant that the estimation may not be accurate with the use of Moore-Penrose inverse in computing the covariance matrix. The correlation matrix of the observed variables is presented in the Table 5-2 and the problem was discussed in Section 5.2. For instance, as seen in Table 5-18, the correlation between latent variables of Perception and Permissiveness ($\rho=1.14$) was over 1.0 in the Permissiveness Model; the high correlation might also explain the insignificant path from perception to permissiveness in the model results.

Table 5-18: Correlation Among Latent Variables (t-statistics) in Permissiveness Model

Latent variable	Perception	Permissiveness	Experience
Perception	1.0		
Permissiveness	1.14154 (11.63)	1.0	
Experience	0.81430 (13.57)	0.87688 (7.57)	1.0

Thus far, more than ten models have been developed, including both conceptual and SEM structural models. However, some of these models had important advantages over others. In order to show reprehensive and meaningful results of the analysis of various aggressive driving behaviors, the comparison and selection with regard to models' fit, significant paths, and explainable coefficients are necessary to examine. This is argued in more detail in the next section.

5.5 Model Selection

Box G. E. P. and Draper, N. R (1987) once said that “All models are wrong, but some are useful” (p. 424). Compared to the SEM structural models, the conceptual models derived from the path analysis showed many advantages. For one, the conceptual models had no limitations and fit the data better. Also, all the paths were explainable and the results provided significant evidence for the hypotheses. Finally, the conceptual models with different predictor variables indicated similar results, so the models were validated. Since conceptual models showed more strength in precise estimation and simple interpretation over SEM structural models, they were used to represent the major findings of this study.

Among all the feasible conceptual models that applied the proposed version of the TRA and were estimated by path analysis, two levels of selection were involved. Firstly, as indicated, two types of conceptual models were built using different variables of acceptance and permissiveness. The variable of acceptance, which was made as a stronger predictor by combining different items, had larger impacts than permissiveness that was adapted from a single item; the conceptual models with the acceptance variable were selected. Secondly, in all Acceptance Models, the model for trivariate behavior which integrated all three behaviors and provided comprehensive insights of perceptions, acceptance, and experience (see Figure 5.8 and Table 5-6), and the model for demographics considering participants’ gender, age, and travel information that facilitated identification of the targeted group of aggressive drivers (see Figure 5.10 and Table 5-10), were selected. In short, the results from two conceptual models of trivariate

behavior (acceptance) and demographic (acceptance) will be regarded as the main results of this research and discussed in detail in the next section.

On the other hand, the SEM structural models provided consistent results with the conceptual models, and the results were very stable in estimating a series of five trials. The results obtained from SEM techniques were also important and could serve as an alternative to the conceptual models. Several approaches of improving SEM models, such as improving the design of questionnaire, will be discussed in the next chapter.

5.6 Major Findings

The objective of this study was to explore the relationship of three aggressive behaviors, DWA, RLR, and speeding, among adult Iowans. The major findings from statistical model results indicated that respondents' accepting/permissive attitudes towards various aggressive driving behaviors were raised by individuals' enhanced perceptions. High frequency of aggressive driving experience was a result of high acceptance/permissiveness and enhanced perceptions of these behaviors. Two or more of the three aggressive behaviors also tended to occur together, meaning drivers who engaged in DWA were also more likely to be involved in RLR and speeding, for example. Demographic factors such as age, gender and VMT also affected individuals' aggressive behaviors while driving. Young males were found to be more aggressive than old and female participants.

5.6.1 Implications of major findings

Several hypotheses were highlighted from this study, specifically:

1) An enhanced perception of DWA increased the perceptions of RLR and speeding. If a driver interprets other drivers' behaviors on the road as being aggressive, he/she tends to notice various aggressive driving behaviors more often.

2) Acceptance of RLR was not significantly influenced by any of the perceptions (DWA, RLR and speeding). As discussed earlier, RLR involves more risks while driving and the crashes are more likely to be fatal. Therefore, people become more cautious about PLR. Regardless of enhanced perceptions, the sub-consciousness and instincts make such behavior less acceptable. Drivers seem to think about RLR differently than they do about speeding.

3) A high acceptance of speeding resulted from an increased perception of speeding and decreased perception of RLR. It is reasonable that as a driver perceives more speeding behaviors while driving, he/she becomes more tolerant of speeding. However, the perception of RLR did not affect the acceptance of RLR; it did not have any significant impacts on acceptance of speeding, either.

4) High frequency of DWA, RLR and speeding experience was rooted in enhanced perceptions and high acceptance of these three aggressive driving behaviors. This finding is consistent with the hypothesis that if a driver has seen the aggressive driving behaviors more often, he/she would learn from others' behaviors and consider them more acceptable, and eventually participate in similar behaviors on his/her own. High frequency of RLR and speeding experience also increased the experience with DWA, which indicated that two or more of the three behaviors often occur together.

5) Age had negative impacts on the aggressive driving behaviors, which indicated that younger age group was more aggressive or had higher aggressive inclinations than older age group. Young people have less life experience comparing to older people, they like thrill seeking and are easily influenced by teenage peers. They tend to be more reckless and careless when driving, such results are not surprising.

6) Gender also had negative impacts on the aggressive driving behaviors in that males were more aggressive or had higher aggressive inclinations than females. As expected, men are less responsible and less careful than women behind the wheel; it is more possible for males to get involved in aggressive driving.

7) VMT had positive, but not significant effects on various aggressive driving behaviors. Drivers who travel a greater number of miles during a 7-day week are more likely to behave aggressively than others, as they have enhanced perceptions and higher acceptance on these behaviors. However, the influence of VMT is not as strong as other demographic characteristics.

8) The permissiveness was estimated as an alternative for acceptance in the conceptual models, as they captured the same characteristics. The results obtained from Permissiveness Models were the same as the Acceptance Models, with slightly weaker estimations. The results confirmed the validity of conceptual models which followed the logic of a proposed version of the TRA and utilized SEM techniques. On the other hand, permissiveness and acceptance also proved to be similar.

9) SEM structural models with latent variables were established as well, and the rough estimations confirmed the results from the conceptual models. The method was examined to be appropriate and optimal once again.

In summary, the results confirmed the logical structure of the proposed version of the TRA and identified the target populations which had higher inclinations to behave aggressively behind the wheel. Results from an analysis of this target group of “young males” was in accordance with findings from previous studies (Horvath and Zuckerman, 1992; Retting et al., 1999; Clarke et al., 2002; Letirand and Delhomme, 2005; Machin and Kim, 2008; Deery, 2013) discussed in Chapter 2 and the descriptive statistics provided in Sections 4.3.1 and 4.3.2. These two findings are probably most often cited, so our consistency with them provides valid evidence for the findings. That is, our results regarding gender and age validate and are consistent with early studies, making our other findings credible as well. As the perception and acceptance of one behavior had significant influence on those of the other two behaviors, the three behaviors were linked and interacted with each other. The results also demonstrated that individuals who engaged in DWA were also more likely to get involved in speeding and RLR, which complied with the findings from past studies that risky behaviors often occur together (CSBTS, 2004). The main findings of this research provide engineers, policy makers, and companies with various interventions and applications, all of which are discussed in the next section.

5.6.2 Application

As the purpose of this study was to explore various behaviors of “aggressive” drivers, and make recommendations for targeted interventions to improve their driving behaviors and reduce crashes, several applications based on the results of the study are presented below.

5.6.2.1 Enforcement

Traditional enforcement to reduce risky driving behaviors includes photo enforcement devices (speed cameras and/or red light cameras) and traffic tickets. As presented in Table A-1, the descriptive statistics of the survey questionnaire indicated that more than one-third (38.9%) of the participants considered enforcement the most effective way to make driving safer in Iowa. Several questions about individuals’ attitudes and opinions on the use of automated enforcement techniques showed that most participants supported using cameras to automatically ticket drivers who are speeding on a major highway (55.0%) or on a city street (56.4%), and to ticket drivers who drive through red lights (70.8%). In addition, the majority (83.9%) of the participants thought that drivers would be more careful if they knew that speed/red light cameras were in place.

Vanlaar, Robertson, and Marcoux (2014) conducted a quasi-experimental study to explore the effect of cameras at intersections on speeding and RLR behaviors using roadside data in Canada. Significant reductions were found in RLR violations after installing cameras at intersections, so that photo enforcement had a favorable impact on speeding and RLR behaviors at intersections. Moreover, McCartt and Hu (2014)

evaluated the impacts of red light camera enforcement and found red light violations were much fewer a year after installing the cameras. In addition, a study conducted in the UK suggested significantly fewer numbers of accidents of all levels of severity at speed camera sites as well (Li, Graham, & Majumdar, 2013). Pauw, Daniels, Brijs, Hermans, and Wets (2014) also found that speed cameras had a protective influence on traffic safety, especially on severe crashes. Factor (2014) estimated the role of traffic tickets on road traffic crashes and found that drivers who received six traffic tickets per year had a higher possibility of being engaged in fatal and severe crashes than the ones who received only one ticket by a factor of 11. Implementing random enforcement programs may significantly reduce traffic violations, as well as fatal and severe crashes.

5.6.2.2 Engineering

Engineers have made great efforts in road and signal design to reduce risky driving, such as speed reduction markings, speed reduction signs/dynamic speed display signs, and traffic timing. From the general results of the survey questionnaire, over a quarter (28.2%) of participants thought engineering interventions were the most effective in making driving safer in Iowa (Table A-1).

Ding, Zhao, Rong, and Ma (2013) evaluated the efficiency of speed reduction markings based on a driving simulation. The analysis of variance (ANOVA) and the contrast analysis (S–N–K method) were performed and transverse speed reduction markings (TSRMs) were found to significantly affect individuals' speed choices and maneuvers.

Another commonly accepted and often implemented speed reduction measure is the signs such as a Reduced Speed Limit Ahead (W3-5 or W3-5a) sign with white retroreflectivity design (MUTCD 2009, Section 2C.38). This sign is used to inform road users that there will be a speed reduction of over 10 mph in the zone ahead. Ron Van Houten and Fabienne Van Houten (1987) examined the effects of a sign with specific wording of “Begin Slowing Here” on speed reduction in Canada. The speeds were measured at three periods of time when the sign was installing, uninstalling, and reinstalling. The results suggested a significant speed reduction among the drivers. In recent years, the use of different dynamic speed display signs (DSDS) has been growing. Gehlerta, Schulzeb, and Schlagb (2012) evaluated the three types of DSDS displaying numeric values related to the driver’s speed in Germany, and each type had a different highlight. They found that all three types led to significant reductions in drivers’ average speed and 85th percentage speed, as well as the percentage of vehicles that were speeding. In the U.S., Riffkin, McMurtry, Heath, and Saito (2008) assessed the effects of Variable Speed Limit (VSL) signs on speed and speed variation in Utah. VSL signs that used to decrease posted speed limits in certain areas were found to have positive impacts on traffic safety due to the reduction of speed and its variation. The three studies provided strong evidence for that prompting signs had important influence on speed reduction.

Apart from speed reduction markings and signs, interventions could also be implemented at traffic signals to discourage aggressive driving behaviors. As mentioned in Chapter 2, aggression may originate from various road conditions includes crowding,

congestion, delays (Jovanovic et al., 2010; Lajunen et al., 1999; Liu & Lee, 2005; Shinar & Compton, 2004;). A well-timed traffic signal design would reduce driver's temptations to speed and run red-lights, as well as to relieve road congestion and delays in an effort to reduce driver's anger and anxiety.

There are also some interventions made which target young drivers for road safety improvement. Parker, Goode, and Salmon (2014) argued to integrate driver-centric interventions with the current prevailing driver-centric approach. The authors proposed an approach based on systems with a consideration of both an individual and other users in the road transport system, as well as their interactions. The alternative approach considers a complicated safety-critical environment and is recognized as a summation of all the elements. The methodology was used in analyzing the Victoria's Kerang rail level crossing incident in 2007, and the results suggested that the system approach was more effective and the most suitable intervention.

5.6.2.3 Education

According to the descriptive statistics of the survey questionnaire, around one-third (30.4%) of survey participants considered education the most effective for making driving safer in Iowa (Table A-1). Various training programs and advertisements are good applications involved in education interventions.

As demonstrated in the model results, young males were found to be more aggressive than older participants and female participants. Many programs have been proposed or implemented to educate young men to reduce their aggressive driving behaviors. A two-year trial study funded by the government of the United Kingdom was

conducted to examine young males' driving behavioral changes. Behavioral performance was measured by an in-vehicle data recorder (IVDR), observers' evaluations, and participants' self-reported surveys and interviews, at three stages of pre-, during, and post-trial. The results showed that the participants improved their driving skills significantly after the trial (Tapp, Pressley, Baugh, & White, 2013). In the U.S., many of the insurance companies such as State Farm Insurance Company offer special training programs to young drivers. The Steer Clear® Driver Program provides a course to help drivers under 25 years old improve their driving skills and meanwhile save money on auto insurance (Statefarm.com). State Farm also awards the drivers who have clear driving experience. Particularly, to educate the "aggressive" drivers, psychology perspective could be considered in controlling individuals' driving aggression. For instance, licenses should specify that an individual has to "stay on their medications." Other approaches might be psychological testing that is used to educate new drivers to their vulnerability for behaving aggressively.

One of the other most well-known influences on human behaviors is advertising. A study in Canada evaluated the impacts of motorcycle advertisements on road safety and the results indicated that advertisements promoted recklessness on the road (Bachand, 1988). However, if the advertisements for motorists could be designed appropriately and emphasize the risk of aggression or recklessness, there could be positive impacts on traffic safety. Hence, advertisements that advocate safe driving would be an effective way to reduce road crashes.

Other than training programs and advertising, there are also some practical interventions to change drivers' behaviors, such as offering advice on drivers' speeding performance, installing in-vehicle telemetry devices, and holding regular meetings on safety topics. These practical interventions might assist drivers in identifying potential hazards on the road (Newnam, Lewis, & Warmerdam, 2014).

5.6.2.4 Technology

In addition to enforcement, engineering, and education, companies also envision profiting from the promotion of merchandise and improvement of marketing strategies to reduce risky driving behaviors. For example, many insurance companies promote in-vehicle safety instruments to monitor and report drivers' behaviors by offering discounts. Various companies also offer new technologies installed on smartphones to reduce driver's temptations to drive riskily, especially for speeding and RLR. For instance, application developers have designed products such as the Key2SafeDriving Key, a patented technology with few options for cutting off the function of texting while an individual is driving, autoreplying with a customized text or voice message to incoming messages and calls, and regulating phone activity until drivers have arrived at their destinations safely (Key2SafeDriving.com). In this way, drivers would be more concentrated on the road environment including the speed limit/reduction signs and traffic signals. Similar smartphone applications are also being invented to monitor drivers' speed and upcoming traffic lights, so that drivers could have better judgments on their speed and make better decisions on whether to clear a certain intersection.

5.7 Summary

This chapter discussed the results of conceptual and structural models based on the proposed version of the TRA and utilized SEM techniques. The relationships among perception of, acceptance/permissiveness of, and experience with various aggressive driving behaviors of adults in Iowa were explored.

The results from different statistical models indicated that the perceptions of adult Iowans on aggressive driving behaviors had significantly positive impacts on their acceptance/permissiveness and experience. Participants' acceptance/permissiveness also positively affected their experience with aggressive driving. Two or more of the three aggressive behaviors also tended to occur together while driving. However, participants' acceptance of RLR might be significantly influenced by their risk perceptions and sub-conscious, which were not measurable in this study. In addition, demographic characteristics and travel status also contributed to aggressive driving behaviors in that male drivers and younger age groups were found to be more aggressive or had a more aggressive inclination than females and older drivers.

As this study aimed to provide interventions, several applications based on the main findings, such as the installation of cameras, use of pavement markings, initiation of training programs, advertising, and merchandized promotions, were also presented. Overall, the study contains a number of valuable findings and provides engineers, policy makers, and companies with various interventions and applications.

The next chapter will present conclusions, limitations, and recommendations for future research to improve the results

CHAPTER 6

CONCLUSIONS, LIMITATIONS, AND RECOMMENDATIONS

6.1 Overview

This study investigated the relationship between perception of, acceptance/permissiveness of, and experience with various aggressive driving behaviors among adult Iowans. Several statistical models using path analysis, which is a special case of SEM, were established to explore the interactions and associations among certain aggressive driving behaviors—DWA, RLR, and speeding. Demographic factors such as age, gender and VMT were also examined to identify a group of aggressive drivers. Concluding remarks are presented in this chapter, followed by a discussion of limitations and recommendations for future research.

6.2 Conclusions

The objective of this study was to investigate the relationship among certain aggressive driving behaviors—DWA, RLR, and speeding—with regard to adult Iowans' perception of, acceptance/permissiveness of, and experience with these behaviors. In a statewide survey questionnaire on Iowans' public opinions of traffic safety, respondents were asked to acknowledge the extent to which they reported witnessing risky behaviors of DWA, RLR, and speeding (perception). They were also asked to express their accepting and permissive attitudes towards these behaviors (acceptance/permissiveness), which were expected to affect their personal experience or engagement in the behaviors (experience). Based on the available data in this study, several modifications were made to the TRA, and the proposed version of the TRA was used to construct models

operating path analysis, which is a special case for SEM techniques. The main findings from statistical model results indicated that if the participants observed others' aggressive driving behaviors more often (enhanced perception), they tended to consider such behaviors more acceptable (high acceptance); enhanced perception and high acceptance collaboratively increased participants' engagement in the behaviors (more experience). Participants also reported engaging in two or more of the three aggressive behaviors at the same time, meaning drivers who engaged in DWA were also more likely to be involved in RLR and speeding, for example. A higher frequency of engaging in one of the three behaviors increased the likelihood of participating in the other two aggressive driving behaviors. However, it was found that running red lights was an exception and the acceptance of RLR was not resultant of any perceptions measured in this study.

When examining the relationship between aggressive driving behaviors and driver's demographic characteristics, it was found that male drivers were more aggressive than female drivers, and the younger age group was more aggressive than the older age group. VMT had fewer impacts on the aggressive driving behaviors.

The findings of this study will provide engineers, policy makers, and companies with various interventions and applications. For example, enforcement such as cameras and traffic tickets which reduce speeding and RLR violations will have a protective influence on traffic safety. From engineering perspective, application of speed reduction markings/signs would reduce speeding-related crashes, and better design of traffic signals could decline individuals' temptations of RLR and relieve their anxiety. In

addition, various education interventions including training programs for young and “aggressive” drivers and advertisement would also raise individuals’ awareness of aggression-related risks and polish their driving skills. Moreover, merchandized promotions and smartphone applications that regulate phone’s activities aim to transfer driver’s centration on the road signs and signals would also reduce speeding and RLR behaviors. All the interventions were recommended to reduce the crashes related to aggressive driving, improve drivers’ behaviors on the road, and therefore, improve the overall traffic safety in Iowa.

6.3 Limitations and Recommendations for Future Research

Although this study revealed the potential relationships among various aggressive driving behaviors of adult Iowans, there are still some limitations. Study limitations and a few recommendations for future research are presented in this subsection.

First of all, the responses on the survey questionnaire were based on self-report, thus their authenticity might be doubtable. Participants’ answers may not have reflected their actual attitudes, acceptance, and behaviors, since they could have had the tendency to conceal or minimize their involvements in these behaviors. For this study, this may mean that the results are inaccurate or underestimate the current state of aggressive driving behaviors among adult Iowans. To address this problem, observational studies involving vehicle instrumentation could be performed to validate the authenticity of participants’ responses. Vehicle instrumentation that generates new knowledge has been widely used in on-road safety research. Comparing the self-reported survey responses

with the observational data would help improve the accuracy of the estimation and provide valid evidence for the findings of this study. Novel findings may also be revealed through such a comparison.

Secondly, the survey questionnaire used in this research was not originally designed for this study, and the data adapted from the questions that used to establish variables did not match with the variables perfectly. The variables were highly correlated with each other, and the high correlations brought some problems to the model construction. In addition, because there were a fewer number of questions on DWA than questions on speeding and RLR, some factors for DWA were immeasurable. Therefore, it was impossible to construct parallel model structures and the paths were also restricted. A large improvement could be made by thinking more systematically through the dimensions of the problem, and then designing questionnaire items to tap into those key dimensions. Future researchers should focus on the intent of the question items and attempt to create a series of items that express a same idea and help explain a concept. Once the questionnaire items have been composed, researchers have a number of choices for response styles, one of which might be Likert-scale.

Because this study did not incorporate the Big Five personality traits (i.e., openness, conscientiousness, extraversion, agreeableness, and neuroticism) and emotional factors such as anger, frustration, and anxious, which were excluded from this dataset, the analysis can be said to not have developed comprehensive models for aggressive driving. Emphasis was also placed on the definition of “aggressiveness” in traffic violations (engagement in DWA, RLR, and speeding behavior) rather than

individual's personality traits and emotions. However, it is necessary to evaluate the impacts of human's conscientiousness and anger since they affect drivers' behaviors directly, as indicated from the literature (Chliaoutakis et al., 2002; Miles and Johnson, 2003; Benfield et al., 2007; Constantinou et al., 2011; Jovanovic et al., 2011; Dahlen et al., 2012; Berdoulat et al., 2013). To address this issue, the design of the survey questionnaire could be modified to obtain more comprehensive insights about driver's personality traits and improve estimation accuracy of aggressive driving behaviors in Iowa. To be specific, more comprehensive questions, such as those considering "what are the antecedents of driving behaviors?," could be added. For example, ideas like those implemented by Anderson and Bushman (2001), who studied aggression when stimulated by violent video games. Similarly, future research could perform an analogy of aggression measurement by designing studies to measure aggression under different traffic conditions, controlling for dimensions of personality. These studies could also include more psychological characteristics and personality traits into the questionnaire. Moreover, it is highly recommended that larger sample sizes of drivers from a younger age group be included, since it is found that younger drivers are more often involved in aggressive driving in this study.

The logic of the TRA variant models is reversible by demonstrating that a participant's experience increases his/her acceptance/permissiveness, and therefore increases his/her perceptions of certain behaviors. The reversed fully-recursive model may also fit as well as the conceptual models proposed in this study, and would be another potential model to employ in investigating aggressive driving behaviors. Future

researchers could develop reversed models for specific utilizations in order to argue that drivers' enhanced perceptions and tolerating attitudes result from their actual experience on certain behaviors, if such data is available. If the specific questions related to perceived behavioral control are available from a modified survey questionnaire, researchers could apply the TPB, an extension of TRA, to explore aggressive driving behaviors among drivers and make comparisons between TPB and the suggested version of TRA. The estimated results might be in accordance with the results gained from TRA, which would again confirm the application of TRA. To summarize, applying various risk theories may help show their differences and provide insight into their advantages and drawbacks in analyzing risk behaviors.

Due to the high correlations among the variables, all path models were estimated as a special case of SEM models where the measurement error was not managed in this study. For future research, one could attempt to treat the items (i.e., perception, acceptance/permissiveness, experience) as indicators of latent variables and estimate latent paths in the model, using a modified dataset which overcomes measurement problems and the problem of deciding on causal order. Two potential resolutions are recommended. Firstly, panel studies may help untangle issues associated with causal order. Study participants could be asked to answer questionnaires within cohorts that extend over a number of years, allowing researchers to examine how drivers have changed their behaviors over time. Secondly, careful development of additional constructs that takes into account alternative theories, such as the one proposed by Gibbons et al. (2014) on risky behaviors, could help create more elaborate models to

provide insights into aggressive behaviors. The new results would either confirm or disconfirm this study's findings, in which way; from there, future researchers could test the validity of the SEM technique and settle on an optimum methodology for similar dataset and studies.

Finally, this study of examining the different aggressive driving behaviors among adults in Iowa may raise the awareness of trends for other states; similar studies could be performed in other states for comparison purposes, either from an engineering or psychological perspective. In this way, the nation-wide intervention approaches such as law enforcement could be implemented, in a bid to improve traffic safety nationally.

BIBLIOGRAPHY

- Ajzen, Icek. (1991). The theory of planned behavior. *Organizational Behavior and Human Decision Processes*, 50, 179-211.
- Ajzen Icek, Martin Fishbein Martin. (1969). The prediction of behavioral intentions in a choice situation. *Journal of Experimental Social Psychology*, 5 (4), 400-416.
- Ajzen Icek, Fishbein Martin. (1970). The prediction of behavior from attitudinal and normative variables. *Journal of Experimental Social Psychology*, 6 (4), 466-487.
- Ajzen, Icek, Fishbein Martin. (1980). *Understanding attitudes and predicting social behavior*. Englewood Cliffs, NJ, Prentice-Hall.
- Ajzen, Icek, Fishbein Martin. (2000). Attitudes and the attitude-behavior relation: Reasoned and automatic processes. In W. Stroebe & M. Hewstone (Eds). *European review of social psychology*, 117-138. New York: Guilford.
- Akerstedt, T., Haraldsson, P. (2001). International consensus meeting on fatigue and the risk of traffic accidents: the significance of fatigue for transportation safety is underestimated. *Lakartidningen*, 98 (25), 3014–3017.
- Albrecht Chris, Li Wanjun, Gkritza Konstantine. (2013). Improving Traffic Safety Culture in Iowa-Phase II. Prepared for Center for Transportation Research and Education (CTRE), Iowa State University, Ames, IA.
- Anderson, C. A., & Bushman, B. J. (2001). Effects of violent video games on aggressive behavior, aggressive cognition, aggressive affect, physiological arousal, and prosocial behavior: A meta-analytic review of the scientific literature. *Psychological science*, 12(5), 353-359.
- Bachand Denis. (1988). The marketing of ideas advertising and road safety. *International Journal of Research in Marketing*, 4 (4), 291-309.
- Baum M. Herbert, Wells K. JoAnn, Lund K. Adrian. (1991). The fatality consequences of the 65 mph speed limits. *Journal of Safety Research*, 22 (4), 171-177.
- Beck H. Kenneth, Yan Fang, Wang Min Qi. (2007). Cell phone users, reported crash risk, unsafe driving behaviors and dispositions: A survey of motorists in Maryland. *Journal of Safety Research*, 38 (6), 683-688.
- Beirness, D.J., Simpson, H.M., Desmond, K. (2005). *The Road Safety Monitor 2004. Drowsy Driving*. Ottawa, Ontario: Traffic Injury Research Foundation.
- Bekker, P.A., Merckens, A., Wansbeek, T.J. (1994). *Identification, Equivalent Models, and Computer Algebra*. Academic Press, New York.

Benfield A. Jacob, Szlemko J. William, Bell A. Paul. (2007). Driver personality and anthropomorphic attributions of vehicle personality relate to reported aggressive driving tendencies. *Personality and Individual Differences*, 42 (2), 247-258.

Berdoulat Emilie, Vavassori David, Sastre Muñoz María Teresa. (2013). Driving anger, emotional and instrumental aggressiveness, and impulsiveness in the prediction of aggressive and transgressive driving. *Accident Analysis & Prevention*, 50, 758-767.

Bollen, K.A. (1989). *Structural Equations with Latent Variables*. Wiley, New York.

Box, G. E. P., and Draper, N. R., (1987), *Empirical Model Building and Response Surfaces*, John Wiley & Sons, New York, NY.

Brady, S.S. (2006). Lifetime community violence exposure and health risk behavior among young adults in college. *Journal of Adolescent Health*, 39, 610–613.

Brian A. Jonah, Nancy E. Dawson. (1982). Predicting reported seat belt use from attitudinal and normative factors. *Accident Analysis & Prevention*, 14 (4), 305-310.

Brian Christopher Tefft. (2012). Prevalence of motor vehicle crashes involving drowsy drivers, United States, 1999–2008. *Accident Analysis & Prevention*, 45, 180-186.

Buss, A. H. (1961). *The psychology of aggression*. New York: Wiley.

Buss, A. H., & Durkee, A. (1957). An inventory for assessing different kinds of hostility. *Journal of Consulting Psychology*, 21, 343–349.

Byrne, B.M. (2001). *Structural Equation Modeling with AMOS: Basic Concepts, Applications, and Programming*. Lawrence Erlbaum Associates, Hillsdale, NJ.

Chang Hsin-Li, Woo T. Hugh, Tseng Chien-Ming, Tseng I-Yen. (2011). Driving behaviors and accident risk under lifetime license revocation. *Accident Analysis & Prevention*, 43 (4), 1385-1391.

Chliaoutakis EI. Joannes, Demakakos Panayotis, Tzamalouka Georgia, Bakou Vassiliki, Koumaki Malamatenia, Darviri Christina. (2002). Aggressive behavior while driving as predictor of self-reported car crashes. *Journal of Safety Research*, 33 (4), 431-443.

Chou S. Patricia, Dawson A. Deborah, Stinson S. Frederick, Huang Boji, Pickering P. Roger, Zhou Yuan, Grant F. Bridget. (2006). The prevalence of drinking and driving in the United States, 2001–2002: Result from the national epidemiological survey on alcohol and related conditions. *Drug and Alcohol Dependence*, 83(2), 137-146.

Clarke, D.D., Ward, P., Truman, W. (2002). In-depth accident causation study of young drivers. Retrieved July 26, 2005, from <<http://www.trl.co.uk/static/dtlr/pdfs/TRL542.pdf/>>.

Constantinou Elena, Panayiotou Georgia, Konstantinou Nikos, Loutsiou-Ladd Anthi, Kapardis Andreas. (2011). Risky and aggressive driving in young adults: Personality matters. *Accident Analysis & Prevention*, 43 (4), 1323-1331.

- Dahlen, E. R., Martin, R. C., Ragan, K., & Kuhlman, M. (2005). Driving anger, sensation seeking, impulsiveness, and boredom proneness in the prediction of unsafe driving. *Accident Analysis and Prevention*, 37, 341–348.
- Dahlen R. Eric, Edwards D. Bryan, Tubré Travis, Zyphur J. Michael, Warren R. Christopher. (2012). Taking a look behind the wheel: An investigation into the personality predictors of aggressive driving. *Accident Analysis & Prevention*, 45, 1-9.
- David C. Schwebel, Joan Severson, Karlene K. Ball, Matthew Rizzo. (2006). Individual difference factors in risky driving: The roles of anger/hostility, conscientiousness, and sensation-seeking. *Accident Analysis & Prevention*, 38 (4), 801-810.
- Deery A. Hamish. (1996). “Hazard and Risk Perception among Young Novice Drivers”. *Journal of Safety Research*, 27 (1), 33-41.
- Deery, H.A., Fildes, B.N. (1999). Young novice driver subtypes: relationship to high-risk behavior, traffic accident record, and simulator driving performance. *Human Factors*, 41 (4), 628–643.
- Den Boon, A.K. (1980). *Opvattingen over Autogrebruik en Milieuvervuiling*. Baschwitz Institute for Public Opinion and Mass Psychology, University of Amsterdam.
- Ding Han, Zhao Xiaohua, Rong Jian, Ma Jianming. (2013). Experimental research on the effectiveness of speed reduction markings based on driving simulation: A case study. *Accident Analysis & Prevention*, 60, 211-218.
- Dingus, T.A., Hardee, H.L., Wierwille, W.W. (1987). Development of models for onboard detection of driver impairment. *Accident Analysis & Prevention*, 19, 271–283.
- Donovan, J.E. (1993). Young adult drinking–driving: behavioral and psychological correlates. *Journal of Studies on Alcohol*, 54, 600–613.
- DrAPER, N.R.; Smith, H. (1998) *Applied Regression Analysis*, Wiley. ISBN 0-471-17082-8 (Chapter 14)
- Dula S. Chris, Geller E.Scott. (2003). Risky, aggressive, or emotional driving: Addressing the need for consistent communication in research. *Journal of Safety Research*, 34 (5), 559-566.
- Duncan, O.D. (1975). *Introduction to Structural Equation Models*. Academic Press, New York.
- Duncan, O.D., Featherman, D.L., Duncan, B. (1972). *Socioeconomic Background and Achievement*. NY: Siminar Press.
- Eby, D, W., Bingham, C, R., Vivoda, J. M., & Ragunathan, T. (2005). Use of booster seats by Michigan children 4-8 years of age. *Accident Analysis and prevention*, 37 (6), 1153-1161.

Eby, D. W., Bingham, C. R., Vivoda, J. M., & Ragnathan, T. (2011). Chapter 16 - Factors Influencing Safety Belt Use, In: Bryan E. Porter, Editor(s), *Handbook of Traffic Psychology*, 215-229.

Efrat Kalanit, Shoham Aviv. (2013). The Theory of Planned Behavior, Materialism, and Aggressive Driving, *Accident Analysis & Prevention*, Available online.

Elmitiny Noor, Yan Xuedong, Radwan Essam, Russo Chris, Nashar Dina. (2010). Classification analysis of driver's stop/go decision and red-light running violation. *Accident Analysis and Prevention*, 42, 101–111.

Engström, J., Aust, M.L., Viström, M. (2010). Effects of working memory load and repeated scenario exposure on emergency braking performance. *Human Factors*, 52 (5), 551–559.

Factor Roni. (2014). The effect of traffic tickets on road traffic crashes. *Accident Analysis & Prevention*, 64, 86-91.

Fishbein, M. (1967). *Attitude and prediction of behavior*. In M. Fishbein (Ed.), Reading in attitude theory and measurement. New York: Wiley.

Fishbein M. and Azjen I. (1975). *Belief, attitude, intention and behavior: an introduction to theory and research*, Addison-Wesley, Reading, MA.

Forward E. Sonja. (2010). Intention to speed in a rural area: Reasoned but not reasonable, *Transportation Research Part F: Traffic Psychology and Behavior*, 13 (4), 223-232.

French, Carl (1996). *Data Processing and Information Technology (10th ed.)*. Thomson. p. 2. ISBN 1844801004.

Friedman, H., Schustack, M. (1999). *Personality classic theories and modern research. (Fifth ed.)*, pp. 204-207. Pearson.

Gehlert Tina, Schulze Christoph, Schlag Bernhard. (2012). Evaluation of different types of dynamic speed display signs. *Transportation Research Part F*, 15, 2012, 667–675.

Gibbons, F. X., Lane, D. J., Gerrard, M., Pomery, E. A., & Lautrup, C. L. (2002). Drinking and driving: A prospective assessment of the relation between risk cognitions and risk behavior. *Risk, Decision and Policy*, 7, 267–283.

Gibbons X. Frederick. Kingsbury H. John, Weng, Chih-Yuan, Gerrard Meg, Cutrona, Carolyn, Wills A Thomas, Stock Michelle. (2014). Effects of perceived racial discrimination on health status and health behavior: A differential mediation hypothesis. *Health Psychology*, Vol 33(1), 11-19.

Glassbrenner, D. (2005). Driver Cell Phone Use in 2005 — Overall Results. *Traffic Safety Facts*, NHTSA.

- Golob F. Thomas. (2003). Structural equation modeling for travel behavior research, *Transportation Research Part B: Methodological*, 37 (1), 1-25.
- Golob, T.F., Hensher, D.A. (1996). Driver behavior of long-distance truck drivers: effects of schedule compliance on drug use and speeding citations. *International Journal of Transport Economics*, 23, 267–301.
- Gray, J.A. (1987). Perspectives on anxiety and impulsivity: a commentary. *Journal of Research in Psychology*, 21, 493–509.
- Gregersen Nils Petter, Bjurulf Per, (1996). Young novice drivers: Towards a model of their accident involvement. *Accident Analysis & Prevention*, 28 (2), 229-241.
- Groeger, J.A., Brown, I.D. (1989). Assessing one's own and others' driving ability: influences of sex, age and experience. *Accident Analysis & Prevention*, 21 (2), 155–168.
- Groeger J.A., Rothengatter J.A. (1998), Traffic psychology and behavior. *Transportation Research Part F: Traffic Psychology and Behaviour*, 1 (1), 1-9.
- Guo Qiao, Johnson C. Anderson, Unger B. Jennifer, Lee Liming, Xie Bin, Chou Chih-Ping, Palmer H. Paula, Sun Ping, Gallaher Peggy, Pentz MaryAnn. (2007). Utility of the theory of reasoned action and theory of planned behavior for predicting Chinese adolescent smoking. *Addictive Behaviors*, 32 (5), 1066-1081.
- Hale, J.L., B.J. & Greene, K.L. (2003). The theory of reasoned action. In J.P. Dillard & M. Pfau (Eds.), *The persuasion handbook: Developments in theory and practice*, 259–286.
- Hanna L.Christian, Laflamme Lucie, Elling Berty, Möller Jette. (2013).Unlicensed driving and other related health risk behaviors: A study of Montana high school students. *Accident Analysis & Prevention*, 54, 26-31.
- Harbeck L. Emma, Glendon A. Ian. (2013). How reinforcement sensitivity and perceived risk influence young drivers' reported engagement in risky driving behaviors. *Accident Analysis & Prevention*, 54, 73-80.
- Heikki Summala. (1996). Accident risk and driver behaviour, *Safety Science*, 22 (1–3), 103-117.
- Horvath, P., Zuckerman, M. (1992). Sensation seeking, risk appraisal, and risky behavior. *Personality and Individual Differences*, 14 (1), 41–52.
- Hu, L., & Bentler, P.M. (1999). Cutoff criteria for fit indexes in covariance structure analysis: 1109 conventional criteria versus new alternatives. *Structural Equation Modeling*, 6, 1–55.

Hutchens Lauren, Senserrick M. Teresa, Jamieson E. Patrick, Romer Dan, Winston K. Flaura. (2008). Teen driver crash risk and associations with smoking and drowsy driving. *Accident Analysis & Prevention*, 40 (3), 869-876.

Ishigami Yoko, Klein M. Raymond. (2009). Is a hands-free phone safer than a handheld phone?. *Journal of Safety Research*, 40 (2), 157-164.

Iversen Hilde. (2004). Risk-taking attitudes and risky driving behaviour, *Transportation Research Part F: Traffic Psychology and Behaviour*, Volume 7 (3), 135-150.

Jewell D. Jeremy, Hupp D.A. Stephen, Segrist J. Daniel. (2008). Assessing DUI risk: Examination of the Behaviors & Attitudes Drinking & Driving Scale (BADDs). *Addictive Behaviors*, 33 (7), 853-865.

Jonah A. Brian, Dawson E. Nancy. (1982). Predicting reported seat belt use from attitudinal and normative factors. *Accident Analysis & Prevention*, 14 (4), 305-310.

Jovanović Dragan, Lipovac Krsto, Stanojević Predrag, Stanojević Dragana. (2011). The effects of personality traits on driving-related anger and aggressive behaviour in traffic among Serbian drivers. *Transportation Research Part F: Traffic Psychology and Behaviour*, 14 (1), 43-53.

Kenneth H. Beck, Fang Yan, Wang Min Qi. (2007). Cell phone users, reported crash risk, unsafe driving behaviors and dispositions: A survey of motorists in Maryland. *Journal of Safety Research*, 38, 683-688.

Lajunen Timo, Parker Dianne, Summala Heikki. (1999). Does traffic congestion increase driver aggression?. *Transportation Research Part F: Traffic Psychology and Behaviour*, 2 (4), 225-236.

Lajunen Timo, Parker Dianne. (2001). Are aggressive people aggressive drivers? A study of the relationship between self-reported general aggressiveness, driver anger and aggressive driving, *Accident Analysis & Prevention*, 33 (2), 243-255.

Letirand Frédéric, Delhomme Patricia. (2005). Speed behavior as a choice between observing and exceeding the speed limit. *Transportation Research Part F: Traffic Psychology and Behaviour*, 8 (6), 481-492.

Li Haojie, Graham J. Daniel, Majumdar Arnab. (2013). The impacts of speed cameras on road accidents: An application of propensity score matching methods. *Accident Analysis & Prevention*, 60, 148-157.

Li Wanjun, Gkritza Konstantina, Albrecht Chris. (2013b). The culture of distracted driving: Evidence from a public opinion survey in Iowa. *Transportation Research Part F: Traffic Psychology and Behaviour*, In Press, Corrected Proof, Available online 8 February 2014.

- Li Y.C., Sze N.N., Wong S.C. (2013). Spatial-temporal analysis of drink-driving patterns in Hong Kong. *Accident Analysis & Prevention*, Available online.
- Liu Bor-Shong, Lee Yung-Hui. (2005). Effects of car-phone use and aggressive disposition during critical driving maneuvers. *Transportation Research Part F: Traffic Psychology and Behaviour*, 8 (4-5), 369-382.
- Lyon, P.K. (1981). Dynamic analysis of attitude-behavior response to transportation service innovation, Report 423-II-2. Prepared for the Office of Policy Research, Urban Mass Transportation Administration, Transportation Center, Northwestern University, Evanston, IL.
- MacCallum, R.C., Browne, M.W., Sugawara, H.M. (1996). Power analysis and determination of sample size for covariance structure modeling. *Psychological Methods*, 1, 130-149.
- Machin M. Anthony, Kim S. Sankey. (2008). Relationships between young drivers' personality characteristics, risk perceptions, and driving behavior. *Accident Analysis & Prevention*, 40 (2), 541-547.
- Maycock, G., Lester, J., & Lockwood, C. R. (1996). The accident liability of car drivers: The reliability of self-reported data. (TRL report 219). Crowthorne, UK: Transport Research Laboratory.
- McCarthy, D. M., Pedersen, S. L., & Leuty, M. E. (2005). Negative consequences and cognitions about drinking and driving. *Journal of Studies on Alcohol*, 66(4), 567-570.
- McCartt T. Anne, Hu Wen. (2014). Effects of red light camera enforcement on red light violations in Arlington County, Virginia. *Journal of Safety Research*, 48, 57-62.
- McDonald, R.P. (1982). A note on the investigation of local and global identifiability. *Psychometrika*, 47, 101-103.
- McKenna, F.P., Horswill, M.S. (2006). Risk taking from the participants' perspective: the case of driving and accident risk. *Health Psychol.* 25, 163-170.
- Miles E. Donald, Johnson L. Gregory. (2003). Aggressive driving behaviors: are there psychological and attitudinal predictors?. *Transportation Research Part F: Traffic Psychology and Behaviour*, 6 (2), 147-161.
- Millar Murray. (2007). The influence of public self-consciousness and anger on aggressive driving, *Personality and Individual Differences*, 43 (8), 2116-2126.
- Miller, K. (2005). *Communications theories: perspectives, processes, and contexts*. New York: McGraw-Hill.

- Mirman H. Jessica, Albert Dustin, Jacobsohn S. Lela, Winston K. Flaura. (2012). Factors Associated With Adolescents' Propensity to Drive With Multiple Passengers and to Engage in Risky Driving Behaviors. *Journal of Adolescent Health*, 50 (6), 634-640.
- Møller Mette , Gregersen Nils Petter. (2008). Psychosocial function of driving as predictor of risk-taking behavior. *Accident Analysis & Prevention*, 40 (1), 209-215.
- Musselwhite Charles. (2006). Attitudes towards vehicle driving behaviour: Categorising and contextualising risk. *Accident Analysis and Prevention*, 38, 324–334.
- Nesbit M. Sundé, Conger C. Judith, Conger J. Anthony. (2007). A quantitative review of the relationship between anger and aggressive driving. *Aggression and Violent Behavior*, 12 (2), 156-176.
- Nesbit M. Sundé, Conger C. Judith. (2012). Predicting aggressive driving behavior from anger and negative cognitions. *Transportation Research Part F: Traffic Psychology and Behaviour*, 15 (6), 710-718.
- Newnam Sharon, Lewis Ioni, Warmerdam Amanda. (2014). Modifying behavior to reduce over-speeding in work-related drivers: An objective approach. *Accident Analysis & Prevention*, 64, 23-29.
- Ng, L., Mannering, F. (1999). Statistical analysis of the impact of traveler advisory systems on driving behavior. Presented at the Annual Meeting of the Transportation Research Board, January 10–14, Washington.
- Palat Blazej, Delhomme Patricia. (2012). What factors can predict why drivers go through yellow traffic lights? An approach based on an extended Theory of Planned Behavior. *Safety Science*, 50, 408-417.
- Papadakaki M., Kontogiannis T., Tzamalouka G., Darviri C., Chliaoutakis J. (2008). Exploring the effects of lifestyle, sleep factors and driving behaviors on sleep-related road risk: A study of Greek driving behaviors on sleep-related road risk: A study of Greek drivers. *Accident Analysis & Prevention*, 40 (6), 2029-2036.
- Papadakaki M., Tzamalouka G., Orsi C., Kritikos A., Morandi A., Gnardellis C., Chliaoutakis J. (2013). Barriers and facilitators of helmet use in a Greek sample of motorcycle riders: Which evidence?. *Transportation Research Part F: Traffic Psychology and Behaviour*, 18, 189-198.
- Parker B. Scott, Goode N., Salmon P. (2014). The driver, the road, the rules. and the rest? A systems-based approach to young driver road safety. *Accident Analysis and Prevention*, Available online 14 February 2014.
- Pauw Ellen De, Daniels Stijn, Brijs Tom, Hermans Elke, Wets Geert. (2014). An evaluation of the traffic safety effect of fixed speed cameras. *Safety Science*, 62, 168-174.

- Porter E. Bryan. (2011). *Handbook of Traffic Psychology*, London: Academic Press.
- Porter E. Bryan and England J. Kelli. (2000). Predicting Red-Light Running Behavior: A Traffic Safety Study in Three Urban Settings. *Journal of Safety Research*, 31 (1), 1–8.
- Porter E. Bryan and Berry D. Thomas. (2001). A nationwide survey of self-reported red light running: measuring prevalence, predictors, and perceived consequences. *Accident Analysis and Prevention*, 33, 735–741.
- Ramayah T., Rouibah Kamel, Gopi M., Rangel John Gary. (2009). A decomposed theory of reasoned action to explain intention to use Internet stock trading among Malaysian investors. *Computers in Human Behavior*, 25(6), 1222-1230.
- Reimer, B., Mehler, B., Coughlin, J., Dusek, J.A. (2011). The impact of a naturalistic hands-free cellular phone task on heart rate and simulated driving performance in two age groups. *Transportation Research Part F: Traffic Psychology and Behavior*, 14 (1), 13–25.
- Reimer, B., Mehler, B., Wang, Y., Coughlin, J.F. (2012). A field study on the impact of variations in short-term memory demands on drivers' visual attention and driving performance across three age groups. *Human Factors*, 54 (3), 454–468.
- Retting, R.A., Williams, A.F., Preusser, D.F., & Weinstein, H.B. (1995). Classifying urban crashes for countermeasure development. *Accident Analysis and Prevention*, 27, 283–294.
- Retting, R.A., & Williams, A.F. (1996). Characteristics of red light violators: Results of a field investigation. *Journal of Safety Research*, 27, 9–15.
- Retting, R.A., Ulmer G. Robert, Williams, F. Allan. (1999). Prevalence and characteristics of red light running crashes in the United States. *Accident Analysis and Prevention*, 31, 687–694.
- Riffkin Matt, McMurtry Thomas, Heath Suellen, Saito Mitsuru. (2008). Variable Speed Limit Signs: Effects on Speed and Speed Variation in Work Zones. Prepared For: Utah Department of Transportation Research and Development Division. Salt Lake City, Utah.
- Robert E. Burnkrant, Thomas J. Page Jr. (1988). The structure and antecedents of the normative and attitudinal components of Fishbein's theory of reasoned action. *Journal of Experimental Social Psychology* 24 (1), 66-87.
- Romer D. (2003). *Reducing Adolescent Risk: Toward an integrated approach*, Sage Press, Thousand Oaks, CA. pp. 1–8.
- Rundmo, T., Iversen, H. (2004). Risk perception and driving behaviour among adolescents in two Norwegian counties before and after a traffic safety campaign. *Safety Science*, 42, 1–21.

- Schafer, J.L. (1997). *Analysis of Incomplete Multivariate Data*. Chapman & Hall, London.
- Shinar, David. (1978). *Psychology on the road: the human factor in traffic safety*. Wiley, New York.
- Shinar David, Compton Richard. (2004). Aggressive driving: an observational study of driver, vehicle, and situational variables. *Accident Analysis & Prevention*, 36 (3), 429-437.
- Shinar, David. (2007). *Traffic safety and human behavior*, London: Elsevier Science.
- Shope T. Jean, Raghunathan E. Trivellore, Patil M. Sujata. (2003). Examining trajectories of adolescent risk factors as predictors of subsequent high-risk driving behavior. *Journal of Adolescent Health*, 32 (3), 214-224.
- Siskind, V. (1996). Does license disqualification reduce reoffence rates?. *Accident Analysis and Prevention*, 28 (4), 519–534.
- Steiger, J.H., Lind, J.C. (1980). Statistically based tests for the number of common factors. Presented at the Annual Meeting of the Psychometric Society, Iowa City, IA.
- Tapp Alan, Pressley Ashley, Baugh Mike, White Paul. (2013). Wheels, skills and thrills: A social marketing trial to reduce aggressive driving from young men in deprived areas. *Accident Analysis & Prevention*, 58, 148-157.
- Taylor, S., & Todd, P. (1995). Understanding the information technology usage: A test of competing models. *Information Systems Research*, 6(2), 144–176.
- Tefft Brian Christopher. (2012). Prevalence of motor vehicle crashes involving drowsy drivers, United States, 1999–2008. *Accident Analysis & Prevention*, 45, 180-186.
- Thomas E Boyce, E.Scott Geller. (2002). An instrumented vehicle assessment of problem behavior and driving style: Do younger males really take more risks?. *Accident Analysis & Prevention*, 34 (1), 51-64.
- Treat, J.R.; Tumbus, N.S.; McDonald, S.T.; Shinar, D.; Hume, R.D.; Mayer, R.E.; Stansifer, R.L.; and Castellan, N.J. (1977). Tri-level study of the causes of traffic accidents: Final report, *National Highway Traffic Safety*, 1.
- Ulleberg Pål, Rundmo Torbjørn. (2003). Personality, attitudes and risk perception as predictors of risky driving behaviour among young drivers. *Safety Science*, 41(5), 427-443.
- Ullman, J.B. (1996). *Structural equation modeling*. In: Tabachnick, B.G., Fidell, L.S. (Eds.), *Using Multivariate Statistics*, third ed. HarPerCollins College Publishers, New York, pp. 709–819.

Van Houten, Ron. and Van Houten, Fabienne. (1987). The Effect of A Specific Prompting Sign on Speed Reduction. *Accident Analysis & Prevention*, 19(2), 115-117.

Vanlaar, W., Simpson, H., Mayhew, D., & Robertson, R. (2008) Fatigued and drowsy driving: A survey of attitudes, opinions and behaviors. *Journal of Safety Research*, 39 (4), pp. 303-309.

Vanlaar Ward, Robertson Robyn, Marcoux Kyla. (2014). An evaluation of Winnipeg's photo enforcement safety program: Results of time series analyses and an intersection camera experiment. *Accident Analysis & Prevention*, 62, 238-247.

Vinje, M. (1981). Children as pedestrians: abilities and limitations. *Accident Analysis and Prevention*, 13, 225-240.

West, R., Hall, J. (1997). The role of personality and attitudes in traffic accident risk. *Applied Psychology: An International Review*, 46 (3), 253–264.

Wickens M. Christine, Mann E. Robert, Stoduto Gina, Anca Ialomiteanu Anca, Smart G. Reginald. (2011). Age group differences in self-reported aggressive driving perpetration and victimization. *Transportation Research Part F: Traffic Psychology and Behaviour*, 14 (5), 400-412.

Wilde, G.J.S. (1994). Target risk; Dealing with the Danger of Death, Disease and Damage in everyday Decisions. PDE Publications, Toronto, Canada.

Wilde, G.J.S. (1998). Risk homeostasis theory: an overview. *Injury Prevention*, 4, 89-91.

Wilde, G.J.S. (2002). Does risk homeostasis theory have implications for road safety. *British Medical Journal*, 324, 1149-1151.

Williams F. Allan, Reinfurt Donald, Wells K. JoAnn. (1996). “Increasing Seat Belt Use in North Carolina”. *Journal of Safety Research*, 27 (1), 33-41.

Wilson, R. J. (1990). The relationship between seat belt non-use to personality, lifestyle and driving record. *Health Education Research: Theory and Practice*, 5(2), 175-185.

Zhao Nan, Reimera Bryan, Mehlera Bruce, D’Ambrosio A. Lisa, Coughlina F. Joseph. (2012). Self-reported and observed risky driving behaviors among frequent and infrequent cell phone users, *Accident Analysis and Prevention*, Article in press. Available online.

Zuckerman, M. (2000). Are you a risk taker? *Psychology Today*, 33(6), 52-57.

APPENDIX A: COMPLETE SURVEY QUESTIONNAIRE AND RESULTS

HELLO, my name is (name). I am calling from the University of Northern Iowa. We are gathering information about traffic safety in Iowa. This project is conducted by the Iowa Department of Transportation. Your telephone number has been chosen randomly, and I would like to ask some questions about driving practices and traffic safety.

Is this **(phone number)**?

If "no,"

Thank you very much, but I seem to have dialed the wrong number. It's possible that your number may be called at a later time. **STOP**

Is this a private residence in Iowa?

If "no,"

Thank you very much, but we are only interviewing private residences in **Iowa. STOP**

Is this a cellular telephone?

[Read only if necessary: "By cellular (or cell) telephone we mean a telephone that is mobile and usable outside of your neighborhood."]

If "yes,"

Thank you very much, but at this time we are only interviewing people on landline telephones in private residences. **STOP**

I need to randomly select one adult who lives in your household to be interviewed. How many members of your household, including yourself, are 18 years of age or older?

__ Number of adults

If "1,"

Are you the adult?

If "yes,"

Then you are the person I need to speak with. Enter 1 man or 1 woman below (Ask gender if necessary). **Go to page 5.**

If "no,"

Is the adult a man or a woman? Enter 1 man or 1 woman below. May I speak with **[fill in (him/her) from previous question]**? **Go to "correct respondent" on the next page.**

How many of these adults are men and how many are women?

__ Number of men

___ Number of women

The person in your household that I need to speak with is.

If "you," go to Consent

If other, ask to speak with him/her or schedule callback.

To the correct respondent:

HELLO, I am calling for the Iowa Department of Transportation from the University of Northern Iowa. My name is **(name)**. We are gathering information from the public about traffic safety in Iowa. Your telephone number has been chosen randomly, and I would like to ask some questions.

Consent

I will not ask for your last name, address, or other personal information that can identify you.

You do not have to answer any question you do not want to, and you can stop the interview at any time. For most people the interview takes about 25 minutes, but it can vary from person to person. There are no direct benefits to you and any risks of participating are similar to those typically encountered in your day to day life. Your individual answers are grouped with those of others to maintain your confidentiality. If you have any questions about the study, I will provide a telephone number for you to call to get more information.

1. Have you driven in the past year?

1. Yes
2. No
7. Don't know/Not sure
9. Refused

2. During the last year, in a typical 7-day week, about how many miles did you drive?

11. None
12. Less than 20 miles
13. 20-99 miles
14. 100-199 miles
15. 200-499 miles
16. 500-999 miles
17. 1000 miles or more
66. I do not drive anymore
77. Don't know/Not sure

99. Refused

3. Overall, do you think driving in Iowa feels safer, less safe, or about the same as it did 5 years ago?

1. Safer
2. About the same
3. Less safe
7. Don't know/Not sure
9. Refused

4. How safe do you feel when driving a licensed motor vehicle on...?

- a. rural gravel roads in Iowa?
- b. city streets in Iowa?
- c. highways and interstates in Iowa?

Would you say...?

1. Very safe,
2. Somewhat safe, or
3. Not at all safe?
6. I have never driven on a [.....]in Iowa
7. Don't know/Not sure
9. Refused

5. Have you made a specific effort to improve or maintain your driving skills in the last 5 years, such as reading about safe driving, looking at the official Iowa driver's manual, or taking a refresher class?

1. Yes
2. No
6. Haven't driven in the last 5 years
7. Don't know/Not sure
9. Refused

6. Thinking about ways to improve driving skills and habits...

- a. Do you think drivers renewing their license should be required to spend 10 to 15 minutes reviewing safe driving tips and updates on laws and road design?
- b. Do you think drivers renewing their license should be required to pass a written test?
- c. Do you think drivers renewing their license should be required to pass a driving test?
- d. Should there be an insurance discount or other incentive for all licensed drivers to take a refresher class to improve their driving skills and knowledge?

1. Yes
2. No
7. Don't know/Not sure
9. Refused

[If Q1=2, skip to Q8]

7. Would you take such a driving class, either online or in person, if you received an insurance discount or other incentive for doing so?

Would you say...

1. Definitely yes,
2. Probably yes,
3. Probably not, or
4. Definitely not?
7. Don't know/Not sure
9. Refused

8a. The Iowa Department of Transportation provides information about road conditions through the Iowa 511 traveler information system. Have you ever used DOT resources to learn about any of the following?

Road driving conditions
 Construction zones
 Road closures and detours
 Weather, winds and temperatures

1. Yes
2. No
7. Don't know/Not sure
9. Refused

[If 8a=2, skip to Q9a]

8b. Did you use the Iowa 511 resources to make your trip faster or to make your trip safer?

1. Faster
2. Safer
3. Both (DO NOT READ)
7. Don't know/Not sure
9. Refused

9a. Which of the following do you think would be most effective in making driving in Iowa safer?

1. Engineering, such as road signs and road design
2. Education, such as driver's education, refresher classes, or public service messages
3. Enforcement, such as fines and penalties for speeding or sending text messages
7. Don't know/Not sure
9. Refused

9b. Which of the following do you think would be least effective in making driving in Iowa safer?

1. Engineering, such as road signs and road design
2. Education, such as driver's education, refresher classes, or public service messages
3. Enforcement, such as fines and penalties for speeding or sending text messages
7. Don't know/Not sure
9. Refused

10. How well do you think the state of Iowa has done in the following areas:

- a. Reducing alcohol-related accidents
- b. Increasing safety belt use
- c. Improving motorcycle safety
- d. Improving the condition and safety of roads
- e. Enforcing the speed limit
- f. Reducing distracted driving
- g. Increasing commercial vehicle safety
- h. Improving emergency medical services
- i. Improving the safety of young drivers
- j. Improving the safety of older drivers

Would you say...

1. Excellent,
2. Good,
3. Fair, or
4. Poor?
7. Don't know/Not sure
9. Refused

11. Thinking of response times and quality of care, how satisfied are you with the emergency medical services in your area?

Would you say...

1. Very satisfied,
2. Somewhat satisfied, or
3. Not very satisfied?
7. Don't know/Not sure
9. Refused

12. Do you support or oppose...

- a. Having high-visibility law enforcement operations
- b. Increasing the dollar amount of fines for speeding
- c. Requiring OWI repeat offenders to use ignition interlock devices for extended periods of time
- d. Requiring motorcycle riders to complete more extensive training
- e. Reinstating a law that requires motorcyclists to wear a helmet
- f. Having a graduated licensing system for motorcyclists that is based on engine size

1. Support
2. Oppose
7. Don't know/Not sure
9. Refused

13a. The next few questions are about Iowa's graduated driver licensing system, or GDL.

In Iowa, drivers go through three levels of licensing: instruction permit with supervised driving, intermediate license with some restrictions, and the full license. In

Iowa, teens can get an instruction permit at age 14. In some states, the age for a first license is older. Do you think 14 is ok, or what other age do you think it should be?

[] = age (if respondent says "ok" insert 14)

77. Don't know/Not sure
99. Refused

13b. Iowa requires teens to have an instruction permit for six months before they are allowed to drive without an adult in the car. Some states require teens to have an instruction permit for 12 months. Do you think Iowa should increase the permit length to 12 months?

1. Yes
2. No
7. Don't know/Not sure
9. Refused

13c. Some states limit the number of young passengers that newly licensed teens can have.

Do you think Iowa should limit newly licensed teen drivers to no more than one teen passenger?

1. Yes
2. No
7. Don't know/Not sure
9. Refused

13d. Iowa currently allows newly licensed teens to drive until 12:30 am. Some states prohibit driving after 10 pm. Do you think Iowa should limit driving after 10 pm for newly licensed teen drivers?

1. Yes
2. No
7. Don't know/Not sure
9. Refused

14. Is it legal or illegal for drivers under 18 to use a cell phone while driving in Iowa?
[Interviewer note: electronic devices that are installed into the car are not considered cell phones for this question.]

1. Legal
2. Illegal
7. Don't know/Not sure
9. Refused

15. Is it legal or illegal to read, write, or send a text message while driving in Iowa?

1. Legal
2. Illegal
7. Don't know/Not sure
9. Refused

16. The use of automated enforcement techniques such as speed cameras and red-light cameras is increasing in Iowa.

- a. Do you support or oppose using cameras to automatically ticket speeding drivers on major highways?

- b. Do you support or oppose using cameras to automatically ticket speeding drivers on city streets?
- c. Do you support or oppose using cameras to automatically ticket drivers who drive through red lights?

1. Support
2. Oppose
7. Don't know/Not sure
9. Refused

17. In your opinion, would drivers be more careful if they knew that speed and red light cameras were in place?

1. Yes
2. No
7. Don't know/Not sure
9. Refused

18. I'm going to read a list of issues involving traffic safety. For each one, I'd like to know how serious a threat to traffic safety you think it is.

- a. People driving after drinking too much alcohol
- b. People running red lights
- c. Excessive speeding
- d. Aggressive driving
- e. Distracted driving
- f. Drowsy driving
- g. Elderly drivers
- h. Young drivers
- i. Drivers using cell phones
- j. People not wearing seatbelts

Would you say ...

1. Very serious threat to traffic safety
2. Somewhat serious
3. Slightly serious
4. Not at all serious
7. Don't know/Not sure
9. Refused

19. How acceptable to you personally think it is for a driver to...?

- a. Drive when they think they may have had too much to drink
- b. Drive when they're so sleepy that they have trouble keeping their eyes open
- c. Drive 10 mph over the speed limit on a city street
- d. Send text messages or emails while driving
- e. Drive through a light that just turned red, when they could have stopped easily
- f. Drive without wearing their seatbelt
- g. Drive 10 mph over the speed limit on a freeway
- h. Talk on a hand-held cell phone while driving
- i. Talk on a hands-free cell phone while driving
- j. Drive through a stop sign if the way looks clear
- k. Make a right turn at a red light without stopping
- l. Drive 10 mph over the speed limit on a rural gravel road

Would you say...

1. Always acceptable,
2. Sometimes acceptable,
3. Seldom acceptable, or
4. Never acceptable?
7. Don't know/Not sure
9. Refused

20. Please tell me how often you have seen other drivers in your area do the following...

- a. Talk on a cell phone while driving
- b. Honk at other drivers
- c. Speed through a yellow traffic light
- d. Drive 10 miles per hour over the speed limit on a major highway
- e. Drive 10 miles per hour over the speed limit on a city street
- f. Drive through red lights on purpose
- g. Drive while tired or sleepy
- h. Tailgate other vehicles
- i. Read or send a text message or email while driving
- j. Become visibly angry at something another driver did
- k. Drive while seeming to be impaired by drug or alcohol use
- l. Drive through a stop sign
- m. Turn right at a red light without stopping
- n. Drive 10 mph over the speed limit on a rural gravel road

Would you say...

1. Every day,
2. A few times a week,

3. A few times a month,
4. Once a month or less, or
5. Never?
7. Don't know/Not sure
9. Refused

[If Q1=2, skip to Q22]

21. In the past 30 days, as the driver of a vehicle, have you...?

Seatbelt use

- a. Allowed passengers to ride in the back seat of your car without wearing their seatbelts
- b. Allowed passengers to ride in the front seat of your car without wearing their seatbelts
- c. Driven without wearing your seatbelt
- d. Asked passengers to wear a seatbelt

Speeding

- e. Been asked by a passenger to slow down or drive more carefully while driving
- f. Driven 10 mph over the speed limit on a highway or interstate
- g. Driven 10 mph over the speed limit on a city street
- h. Felt pressure from other drivers to drive faster
- i. Driven 10 mph over the speed limit on a rural gravel road

Lights/stop signs

- j. Driven through a light that has just turned red, when you could have stopped safely
- k. Sped up to get through a yellow light before it changed
- l. Turned right at a red light without stopping
- m. Driven through a stop sign

Drinking

- n. Driven when you thought your blood alcohol content was above the legal limit
- o. Driven when you thought your blood alcohol content was a little below the legal limit

Cell phone use

- p. Talked on any kind of cell phone while you were driving
- q. Read or sent a text message or email while you were driving

Other

- r. Driven with an expired license
- s. Driven when you were so tired that you had a hard time keeping your eyes open
- t. Tailgated another vehicle
- u. Became extremely angry at something another driver did
- v. Honked at other drivers
- w. Tried to avoid driving on a certain road because you felt it was dangerous

1. Yes
2. No
7. Don't know/Not sure
9. Refused

22. If you have driven 10 mph or more over the speed limit in the past 5 years, was it usually because you...

1. enjoyed the thrill of driving fast,
2. were running late,
3. were not paying attention to your speed, or
4. were keeping up with the flow of traffic
8. Didn't drive 10 mph over in past 5 years
7. Don't know/Not sure
9. Refused

23a. What do you think the speed limit is on rural gravel roads?

- ___ ___ Miles per hour
- 76 76 mph or higher
 - 77 Don't know/Not sure
 - 88 Depends on time of day
 - 99 Refused

[IF Q23a <> 88, SKIP TO 24a]

23b. [INTERVIEWER: ENTER DAYTIME LIMIT BELOW]

- ___ ___ Daytime Limit
- 76 76 mph or higher
 - 77 Don't know/Not sure
 - 99 Refused

23c. [INTERVIEWER: ENTER NIGHTTIME LIMIT BELOW]

- ___ ___ Nighttime Limit
- 76 76 mph or higher
 - 77 Don't know/Not sure
 - 99 Refused

24. I'm going to read a list of things that might be distracting for some drivers. Please tell me whether you find it very distracting, somewhat distracting, or not at all distracting to...

- a. To have the radio on or music playing.
- b. To have passengers in your car having conversations or interacting.
- c. To have children sitting in the backseat.
- d. To drive through an area with a lot of commercial signage such as billboards.
- e. To use a GPS device while driving.
- f. To make or receive cell phone calls.
- g. To receive text messages or e-mails.

Would you say it is...

- 1. Very distracting,
- 2. Somewhat distracting, or
- 3. Not at all distracting?
- 6. I have never been in that situation
- 7. Don't know/Not sure
- 9. Refused

25. In the past 30 days, have you been required or expected to talk on your cell phone while driving because of work?

- 1. Yes
- 2. No
- 7. Don't know/Not sure
- 9. Refused

26. In the past 30 days, have you been required or expected to send or receive a text message or e-mail on your cell phone while driving because of work?

- 1. Yes
- 2. No
- 7. Don't know/Not sure
- 9. Refused

27. When you ride a bicycle, do you usually wear a helmet?

- 1. Yes
- 2. No
- 6. I do not ride a bicycle
- 7. Don't know/Not sure
- 9. Refused

28. When you ride a motorcycle, do you usually wear a helmet?

1. Yes
2. No
6. I do not ride a motorcycle
7. Don't know/Not sure
9. Refused

29. About how many people do you think died last year from motor vehicle accidents in Iowa? Even if you don't know the exact number, please give me your best guess.
 _____ (Range 0-999,995)

- 999,996. 999,996 or more
 999,997. Don't know/Not sure
 999,999. Refused

30. Please tell me whether you strongly agree, agree, disagree, or strongly disagree with each of the following statements.

- a. There isn't much chance of an accident if I am careful when speeding.
- b. There isn't much chance of an accident if I am careful when driving after drinking alcohol.
- c. Driving when you are tired increases the chance you might have an accident.
- d. Driving while talking on a cell phone increases the chance you might have an accident.
- e. Driving while eating or drinking increases the chance you might have an accident.
- f. The chance of being caught is small for not wearing a seatbelt.
- g. The chance of being caught is small for driving after drinking alcohol.
- h. The chance of being caught is small for speeding.
- i. The chance of being caught is small for running a red light.
- j. The chance of being caught is small for sending or receiving a text message while driving.

Would you...

1. Agree strongly,
2. Agree somewhat,
3. Disagree somewhat, or
4. Disagree strongly?
7. Don't know/Not sure
9. Refused

31. Which one of the following most motivates you to drive safer? Is it ...

1. Your own safety
2. Safety of others

3. Fear of getting caught driving recklessly, or
4. Setting a good example?
7. Don't know/Not sure
8. None of these
9. Refused

32. I have a few last questions about your background and we'll be finished. What types of vehicles do you drive? (Check all that apply.)

1. Car
2. Pickup truck or van
3. Motorcycle
4. Commercial vehicle
5. Other [Specify:]
8. No vehicles
7. Don't know/Not sure
9. Refused

33. Do you have a valid motor vehicle driver's license?

1. Yes
2. No, do not have a license
3. No, current license suspended
7. Don't know/Not sure
9. Refused

34. Has your license ever been suspended or revoked?

1. Yes
2. No
7. Don't know/Not sure
9. Refused

35. How many traffic tickets, if any, have you gotten in the past 2 years for moving violations, including any that were reduced or dismissed?

- _____ # 0-20
77. Don't know/Not sure
 99. Refused

36. During the past 2 years, how many accidents have you been in while you were driving?

- _____ # 0-20

77. Don't know/Not sure
99. Refused

If 36 = 0, skip to 38

37. Did distracted driving play a role in any of these accidents?

1. Yes
2. No
7. Don't know/Not sure
9. Refused

38. Are you...

1. Male
2. Female

39. What is your current age?

- _____ [range 0-96]
96. 96 or older
97. Don't know/Not sure
99. Refused

40a. How many children under age 5 currently live in your household?

- [] children under 5
77. Don't know/Not sure
99. Refused

40b. How many children ages 5 through 17 currently live in your household?

- [] children
77. Don't know/Not sure
99. Refused

41. What is the highest level of education you have completed?

1. Never attended school or only attended kindergarten
2. Grades 1-8 (elementary)
3. Grades 9-11 (some high school)
4. Grade 12 or GED (high school graduate)
5. College 1 year to 3 years (some college or technical school)
6. College 4 years or more (college grad with BA/BS, etc.)

- 7. Graduate degree completed (MA, MS, MFA, MBA, MD, PhD, etc.)
- 7. Don't know/Not sure
- 9. Refused

42. Which of the following best describes where you live? Do you live...

- 1. On a farm or in an open rural area,
- 2. In a small town of less than 5,000 persons,
- 3. In a large town of 5,000 to less than 25,000 persons,
- 4. In a city of 25,000 to less than 50,000 persons, or
- 5. In a city of 50,000 or more persons?
- 7. Don't know/Not sure
- 9. Refused

43. Which of the following best describes where you work? Do you work...

- 1. On a farm or in an open rural area,
- 2. In a small town of less than 5,000 persons,
- 3. In a large town of 5,000 to less than 25,000 persons,
- 4. In a city of 25,000 to less than 50,000 persons,
- 5. In a city of 50,000 or more persons, or
- 6. Do you work on the road, such as in sales, delivery, utility, bus or truck driving, law enforcement, road worker, repair calls, and so forth?
- 8. Not currently working
- 7. Don't know/Not sure
- 9. Refused

**44. What is your annual household income from all sources?
Is it...**

- 1. Less than \$25K
- 2. \$25K to \$49K
- 3. \$50K to \$74K
- 4. \$75k - \$99k
- 5. \$100k or more
- 7. Don't know/Not sure
- 9. Refused

45. Are you of Hispanic, Latino, or Spanish origin?

- 1. Yes
- 2. No
- 7. Don't know/Not sure
- 9. Refused

46. Which of the following best describes your race? Would you say... [SELECT ONLY ONE]

1. White,
2. African American or Black,
3. Asian,
4. American Indian or Alaska Native,
5. Native Hawaiian or Other Pacific Islander, or
6. Other [Specify:_____]
7. Don't know/Not sure
9. Refused

47. What county do you live in?

- _____ County
7. Don't know/Not sure
 9. Refused

48. What is your ZIP Code?

- []
77777. Don't know/Not sure
 99999. Refused

49. How many landline telephone numbers are used in your household to make or receive phone calls?

- _ Residential telephone numbers [6 = 6 or more]
- 7 Don't know / Not sure
 - 9 Refused

50. Thinking about all the phone calls that you receive on your landline and cell phone, what percent, between 0 and 100, are received on your cell phone?

- __ _ Enter percent (1 to 100)
- 8 8 8 Zero
 - 7 7 7 Don't know / Not sure
 - 9 9 9 Refused

Table A-1: Public Opinions to the Identified 11 High-level Goals, with the Inclusion of Demographic Information (adopted from Albrecht et al., 2013)

<i>Improve EMS Response</i>	
Q11: Thinking of response times and quality of care, how satisfied are you with the emergency medical services in your area?	1. Very satisfied: 57.8% 2. Somewhat satisfied: 32.4% 3. Not very satisfied: 3.3%
Q10: How well do you think the state of Iowa has done in... h: improving emergency medical services?	1. Excellent: 20.5% 2. Good: 54.1% 3. Fair: 14.9% 4. Poor: 2.1%
<i>Toughen Law Enforcement and Prosecution</i>	
Q9a: Which of the following do you think would be most effective in making driving in Iowa safer?	1. Enforcement: 38.9% 2. Education: 30.4% 3. Engineering: 28.2%
Q9b: Which of the following do you think would be least effective in making driving in Iowa safer?	1. Engineering: 34.5% 2. Enforcement: 33.1% 3. Education: 25.3%
Q12: Do you support or oppose? a. having high-visibility law enforcement operations b. Increasing the dollar amount of fines for speeding c. Requiring OWI repeat offenders to use ignition interlock devices for extended periods of time	a. Support: 85.2%, Oppose: 12.1% b. Support: 37.8%, Oppose: 59.9% c. Support: 89.2% Oppose: 9.2%
<i>Increase Safety Belt Use</i>	
Q10: How well do you think the state of Iowa has done in... b: Increasing safety belt use	1. Excellent: 30.6% 2. Good: 51.7% 3. Fair: 13.7% 4. Poor: 1.8%
Q18: How serious a threat to traffic safety you think it is: j: People not wearing seat belts	1. Very serious threat to traffic safety: 47.2% 2. Somewhat serious: 32.8% 3. Slightly serious: 12.4% 4. Not at all serious: 7.6%

Table A-1 continued: Public Opinions to the Identified 11 High-level Goals, with the Inclusion of Demographic Information (adopted from Albrecht et al., 2013)

Q19: How acceptable to you personally think is it for a driver to: f. Drive without wearing their seat belt	<ol style="list-style-type: none"> 1. Always acceptable: 5.1% 2. Sometimes acceptable: 17.6% 3. Seldom acceptable: 10.8% 4. Never acceptable: 66.6%
Q21: In the past 30 days, as the driver of a vehicle, have you ... a. Allowed passengers to ride in the back seat of your car without wearing their seat belts? b. Allowed passengers to ride in the front seat of your car without wearing their seat belts? c. Driven without wearing your seat belt? d. Asked passengers to wear a seat belt?	<ol style="list-style-type: none"> a. Yes: 32.2%, No: 67.8% b. Yes: 7.1%, No: 92.9% c. Yes: 16.3%, No: 83.7% d. Yes: 68.0%, No: 32.0%
Q30: Please tell me whether you strongly agree, agree, disagree, or strongly disagree with the following. f. the chance of being caught is small for not wearing a seat belt	<ol style="list-style-type: none"> 1. Strongly agree: 4.6% 2. Agree: 39.1% 3. Disagree: 46.8% 4. Strongly disagree: 9.5%
<i>Reduce Speeding-Related Crashes</i>	
Q10: How well do you think the state of Iowa has done in ... e: enforcing the speed limit	<ol style="list-style-type: none"> 1. Excellent: 13.0% 2. Good: 52.9% 3. Fair: 27.6% 4. Poor: 6.2%
Q16: The use of automated enforcement techniques is increasing in Iowa, do you support or oppose using cameras to automatically ticket speeding drivers on... a. Major highway b. City streets c. Ticket drivers who drive through red light	<ol style="list-style-type: none"> a. Support: 55.0%, Oppose: 45.0% b. Support: 56.4%, Oppose: 43.6% c. Support: 70.8%, Oppose: 29.2%
Q17. In your opinion, would drivers be more careful if they knew that speed/red light cameras were in place?	<ol style="list-style-type: none"> 1. Yes: 83.9% 2. No: 16.1%
Q18. How serious a threat to traffic safety you think it is: c. Excessive speeding	<ol style="list-style-type: none"> 5. Very serious threat to traffic safety: 66.2% 6. Somewhat serious: 28.3% 7. Slightly serious: 4.2% 8. Not at all serious: 1.2%

Table A-1 continued: Public Opinions to the Identified 11 High-level Goals, with the Inclusion of Demographic Information (adopted from Albrecht et al., 2013)

<p>Q19. How acceptable to you personally think it is for a driver to...?</p> <p>c. Drive 10 mph over the speed limit on a city street</p> <p>g. Drive 10 mph over the speed limit on a freeway</p> <p>l Drive 10 mph over the speed limit on a rural gravel road</p>	<p>c. Always: 0.9%, Sometimes: 12.1%, Seldom: 10.7%, Never: 76.4%</p> <p>g. Always: 9.2%, Sometimes: 44.0%, Seldom: 13.1%, Never acceptable: 33.7%</p> <p>i. Always: 3.3%, Sometimes: 21.7%, Seldom: 13.1%, Never: 61.9%</p>
<p>Q20. Please tell me how often you have seen other drivers in your area do the following...</p> <p>c. Speed through a yellow traffic light</p> <p>d. Drive 10 miles per hour over the speed limit on a major highway</p> <p>e. Drive 10 miles per hour over the speed limit on a city street</p> <p>n. Drive 10 mph over the speed limit on a rural gravel road</p>	<p>c. Every day: 35.7%, A few times a week: 27.0%, A few times a month: 17.7%, Once a month or less: 13.5%, Never: 6.2%</p> <p>d. Every day: 49.0%, A few times a week: 25.0%, A few times a month: 14.9%, Once a month or less: 9.9%, Never: 1.4%</p> <p>e. Every day: 28.6%, A few times a week: 25.8%, A few times a month: 15.7%, Once a month or less: 22.1%, Never: 7.8%</p> <p>n. Every day: 11.3%, A few times a week: 12.9%, A few times a month: 16.4%, Once a month or less: 30.4%, Never: 29.0%</p>
<p>Q21. In the past 30 days, as a driver of a vehicle, have you ... Speeding?</p> <p>j. Been asked by a passenger to slow down or drive more carefully while driving</p> <p>k. Driven 10 mph over the speed limit on a highway or interstate</p> <p>l. Driven 10 mph over the speed limit on a city street</p> <p>m. Felt pressure from other drivers to drive faster</p> <p>n. Driven 10 mph over the speed limit on a rural gravel road</p>	<p>e. Yes: 16.7%, No: 83.3%</p> <p>f. Yes: 48.4%, No: 51.6%</p> <p>g. Yes: 12.1%, No: 87.9%</p> <p>h. Yes: 48.3%, No: 51.7%</p> <p>i. Yes: 14.3%, No: 85.7%</p>

Table A-1 continued: Public Opinions to the Identified 11 High-level Goals, with the Inclusion of Demographic Information (adopted from Albrecht et al., 2013)

Q22. If you have driven 10 mph or more over the speed limit in the past 5 years, was it usually because you... 1. enjoyed the thrill of driving fast, 2. were running late 3. were not paying attention to your speed 4. were keeping up with the flow of traffic 5. Something else	5 1.1% 6 19.5% 7 17.7% 8 53.1% 9 8.5%
Q23. What do you think the speed limit is on rural gravel roads?	1. 55mph: 27.0% 2. 45mph: 27.5% 3. 50mph: 11.3% 4. 35mph: 11.3%
Q30: Please tell me whether you strongly agree, agree, disagree, or strongly disagree with each of the following statements. a. There isn't much chance of an accident if I am careful when speeding. h. The chance of being caught is small for speeding	1. Strongly agree: 3.0%, Agree: 30.1%, Disagree: 46.8%, Strongly disagree: 20.0% h. Strongly agree: 2.5%, Agree: 35.3%, Disagree: 52.2%, Strongly disagree: 10.0%
<i>Reduce Alcohol-Related Crashes</i>	
Q10: How well do you think the state of Iowa has done in the following areas: a. Reducing alcohol-related accidents	1. Excellent: 10.6% 2. Good: 48.5% 3. Fair: 27.5% 4. Poor: 8.4%
Q18. How serious a threat to traffic safety you think it is? a. People driving after drinking too much alcohol	1. Very serious threat to traffic safety: 91.8% 2. Somewhat serious: 6.2% 3. Slightly serious: 1.9% 4. Not at all serious: 0.2%
Q19. How acceptable to you personally think it is for a driver to...? a. Drive when they think they may have had too much to drink	1. Always acceptable: 0.5% 2. Sometimes acceptable: 1.8% 3. Seldom acceptable: 3.1% 4. Never acceptable: 94.6%
Q20. Please tell me how often you have seen other drivers in your area do the following... k. Drive while seeming to be impaired by drug or alcohol use	1. Every day: 2.5% 2. A few times a week: 8.6% 3. A few times a month: 15.7% 4. Once a month or less: 45.3% 5. Never: 27.9%

Table A-1 continued: Public Opinions to the Identified 11 High-level Goals, with the Inclusion of Demographic Information (adopted from Albrecht et al., 2013)

Q21. In the past 30 days, as the driver of a vehicle, have you ... Drinking? n. Driven when you thought your blood alcohol content was above the legal limit o. Driven when you thought your blood alcohol content was a little below the legal limit	n. Yes: 5.1%, No: 94.9% o. Yes: 15.1%, No: 84.9%
Q30: Please tell me whether you strongly agree, agree, disagree, or strongly disagree with the following. b. There isn't much chance of an accident if I am careful when driving after drinking alcohol g. The chance of being caught is small for driving after drinking alcohol	b. Strongly agree: 0.7%, Agree: 5.8%, Disagree: 39.7%, Strongly disagree: 53.8% g. Strongly agree: 3.1%, Agree: 29.6%, Disagree: 51.3%, Strongly disagree: 16.0%
<i>Improve Commercial Vehicle Safety</i>	
Q10g.: How well do you think the state of Iowa has done in increasing commercial vehicle safety:	1. Excellent: 9.2% 2. Good: 48.2% 3. Fair: 27.0% 4. Poor: 5.3%
<i>Improve Motorcycle Safety</i>	
Q10. How well do you think the state of Iowa has done in the following areas: c. Improving motorcycle safety	1. Excellent: 6.4% 2. Good: 32.1% 3. Fair: 30.1% 4. Poor: 15.2%
Q12. Do you support or oppose... d. Required motorcycle riders to complete more extensive training e. Reinstating a law that requires a helmet f. Having a graduated licensing system for motorcyclists that is based on engine size	d. Support: 56.3%, Oppose: 36.3% e. Support: 68.0%, Oppose: 29.0% f. Support: 50.8%, Oppose: 34.6%
Q28. When you ride a motorcycle, do you usually wear a helmet?	1. Yes: 55.2% 2. No: 44.8%
<i>Improve Young Driver Education</i>	
Q10. How well do you think the state of Iowa has done in the following areas: i. Improving the safety of young drivers	1. Excellent: 6.8% 2. Good: 39.3% 3. Fair: 36.8% 4. Poor: 10.4%

Table A-1 continued: Public Opinions to the Identified 11 High-level Goals, with the Inclusion of Demographic Information (adopted from Albrecht et al., 2013)

Q18. How serious a threat to traffic safety you think it is? h. Young drivers	1. Very serious threat to traffic safety: 20.4% 2. Somewhat serious: 56.3% 3. Slightly serious: 19.2% 4. Not at all serious: 4.0%
<i>Improve Older Driver Safety</i>	
Q10. How well do you think the state of Iowa has done in the following areas: j. Improving the safety of older drivers	1. Excellent: 3.7% 2. Good: 27.5% 3. Fair: 37.4% 4. Poor: 20.1%
Q18. How serious a threat to traffic safety you think it is? g. Elderly drivers	1. Very serious threat to traffic safety: 21.9% 2. Somewhat serious: 55.0% 3. Slightly serious: 15.4% 4. Not at all serious: 7.6%
<i>Strengthen Teenage Licensing Process</i>	
Q13a. In Iowa, teens can get an instruction permit at age 14. In some states, the age for a first license is older. Do you think 14 is ok, or what other age do you think it should be?	13: 0.5% 14: 58.4% 15: 9.5% 16: 25.7% 17: 1.0% 18: 4.9%
Q13b. Do you think Iowa should increase the permit length to 12 months? (teen)	Yes: 62.4% No: 37.6%
Q13c. Do you think Iowa should limit newly licensed teen drivers to no more than one teen passenger?	Yes: 72.4% No: 27.6%
Q13d. Do you think Iowa should limit driving after 10 pm for newly licensed teen drivers?	Yes: 55.4% No: 44.6%
<i>Reduce Distracted Driving</i>	
Q10. How well do you think the state of Iowa has done in the following areas: f. Reducing distracted driving	1. Excellent: 6.1% 2. Good: 28.0% 3. Fair: 42.4% 4. Poor: 20.2%
Q14. Is it legal or illegal for driver under 18 to use a cell phone for any purpose while driving in Iowa?	1. Legal: 13.3% 2. Illegal: 86.7%
Q15. For adults, is it legal or illegal to read, write, or send a text message while driving in Iowa?	1. Legal: 11.2% 2. Illegal: 88.8%

Table A-1 continued: Public Opinions to the Identified 11 High-level Goals, with the Inclusion of Demographic Information (adopted from Albrecht et al., 2013)

<p>Q18. How serious a threat to traffic safety you think it is? e. Distracted Driving i. Drivers using cell phones</p>	<p>e. Very serious threat to traffic safety: 71.8%, Somewhat serious: 24%, Slightly serious: 3.1%, Not at all serious: 1.1% i. Very serious threat to traffic safety: 57.6%, Somewhat serious: 32.0%, Slightly serious: 8.3%, Not at all serious: 2.1%</p>
<p>Q19. How acceptable to you personally think it is for a driver to...? d. Send text messages or emails while driving h. Talk on a hand-held cell phone while driving i. Talk on a hand-free cell phone while driving</p>	<p>d. Always acceptable: 1.4%, Sometimes acceptable: 4.6%, Seldom acceptable: 5.7%, Never acceptable: 88.4% h. Always acceptable: 3.2%, Sometimes acceptable: 35.8%, Seldom acceptable: 15.4%, Never acceptable: 45.6% i. Always acceptable: 19.9%, Sometimes acceptable: 52.2%, Seldom acceptable: 10.5%, Never acceptable: 17.5%</p>
<p>Q20. Please tell me how often you have seen other drivers in your area do the following... a. Talk on a cell phone while driving i. Read or send a text message or email while driving</p>	<p>a. Every day: 71.7%, A few times a week: 18.4%, A few times a month: 4.4%, Once a month or less: 3.3%, Never: 2.2% i. Every day: 35.0%, A few times a week: 29.5%, A few times a month: 13.4%, Once a month or less: 9.8%, Never: 12.2%</p>
<p>Q21. In the past 30 days, as the driver of a vehicle, have you...Cell phone use ? p. Talked on any kind of cell phone while driving q. Read or sent a text message or email while driving</p>	<p>p. Yes: 66.8%, No: 33.2% q. Yes: 19.1%, No: 80.9%</p>

Table A-1 continued: Public Opinions to the Identified 11 High-level Goals, with the Inclusion of Demographic Information (adopted from Albrecht et al., 2013)

<p>Q24. Please tell me whether you find it very distracting, somewhat distracting, or not at all distracting to...</p> <p>a. To have the radio on or music playing</p> <p>b. To have passengers in your car having conversations or interacting</p> <p>c. To have children sitting in the backseat</p> <p>d. To drive through an area with a lot of commercial signage such as billboards</p> <p>e. To use a GPS device while driving</p> <p>f. To make or receive cell phone calls</p> <p>g. To receive text messages or emails</p>	<p>a. Very distracting: 1.2%, Somewhat distracting: 20.1%, Not at all distracting: 78.7%</p> <p>b. Very distracting: 2.1%, Somewhat distracting: 42.7%, Not at all distracting: 55.2%</p> <p>c. Very distracting: 7.9%, Somewhat distracting: 48.6%, Not at all distracting: 43.4%</p> <p>d. Very distracting: 12.7%, Somewhat distracting: 44.1%, Not at all distracting: 43.3%</p> <p>e. Very distracting: 10.8%, Somewhat distracting: 49.9%, Not at all distracting: 39.3%</p> <p>f. Very distracting: 35.5%, Somewhat distracting: 52.7%, Not at all distracting: 11.8%</p> <p>g. Very distracting: 84.3%, Somewhat distracting: 11.9%, Not at all distracting: 3.7%</p>
<p>Q25. In the past 30 days, have you been required or expected to talk on your cell phone while driving because of work?</p>	<p>Yes: 22.5%</p> <p>No: 77.5%</p>
<p>Q26. In the past 30 years, have you been required or expected to send or receive a text message or e-mail on your cell phone while driving because of work?</p>	<p>Yes: 5.0%</p> <p>No: 95.0%</p>
<p>Q30. Please tell me whether you strongly agree, disagree, or strongly disagree with each of the following statements.</p> <p>d. Driving while talking on a cell phone increase the chance you might have an accident</p> <p>e. Driving while eating or drinking increases the chance you might have an accident</p> <p>j. The chance of being caught is small for sending or receiving a text message while driving</p>	<p>d. Strongly agree: 18.8%, Agree: 71.6%, Disagree: 8.5%, Strongly disagree: 1.1%</p> <p>e. Strongly agree: 10.9%, Agree: 77.5%, Disagree: 11.4%, Strongly disagree: 0.2%</p> <p>j. Strongly agree: 10.4%, Agree: 63.6%, Disagree: 22.8%, Strongly disagree: 3.2%</p>

Table A-1 continued: Public Opinions to the Identified 11 High-level Goals, with the Inclusion of Demographic Information (adopted from Albrecht et al., 2013)

Q36. During the past 2 years, how many accidents have you been in while you were driving?	0: 86.4% 1: 10.6% 2: 2.4% 3: 0.3% 4: 0.0% 5: 0.2%
Q37. In how many of these accidents did distracted driving play a role?	0: 71.5% 1: 19.9% 2: 5.3% 3: 2.0% 5: 1.4%
<i>Demographic and Socio-economic</i>	
Q38. And you are... 1. Male 2. Female	1: 455 (41.8%) 2: 633 (58.2%)
Q39. What is your current age? 1. 18-25 years old 2. 26-39 years old 3. 40-64 years old 4. 65 and older 7. Don't know/Not sure 9. Refused	1: 63 (5.8%) 2: 157 (14.4%) 3: 520 (47.8%) 4: 340 (31.3%) 7: 1 (0.1%) 9: 7 (0.6%)
Q40a. How many children under age 5 currently live in your household?	0: 962 (88.4%) 1: 79 (7.3%) 2: 34 (3.1%) 3: 11 (1.0%) 4: 1 (0.1%) 5: 1 (0.1%)

Table A-1 continued: Public Opinions to the Identified 11 High-level Goals, with the Inclusion of Demographic Information (adopted from Albrecht et al., 2013)

<p>Q41: What is the highest level of education you have completed?</p> <p>12. Grades 1-8 (elementary)</p> <p>13. Grades 9-11 (some high school)</p> <p>14. Grade 12 or GED (high school graduate)</p> <p>15. College 1 year to 3 year (some college or technical school)</p> <p>16. College 4 years or more (college grad with BA/BS, etc.)</p> <p>17. Graduate degree completed (MA, MS, MFA, MBA, MD, PhD, etc.)</p>	<p>12: 13 (1.2%)</p> <p>13: 21 (1.9%)</p> <p>14: 325 (29.9%)</p> <p>15: 349 (32.1%)</p> <p>16: 265 (24.4%)</p> <p>17: 113 (10.4%)</p> <p>99 Refused: 2 (0.2%)</p>
<p>Q42: Which of the following best describes where you live?</p> <p>1. On a farm or in an open rural area</p> <p>2. In a small town of less than 5,000 persons</p> <p>3. In a large town of 5,000 to less than 25,000 persons</p> <p>4. In a city of 25,000 to less than 50,000 persons</p> <p>5. In a city of 50,000 or more persons</p> <p>7. Don't know/Not sure</p>	<p>1: 246 (22.6%)</p> <p>2: 302 (27.8%)</p> <p>3: 183 (16.8%)</p> <p>4: 109 (10.0%)</p> <p>5: 242 (22.2%)</p> <p>7: 6 (0.6%)</p>

Table A-1 continued: Public Opinions to the Identified 11 High-level Goals, with the Inclusion of Demographic Information (adopted from Albrecht et al., 2013)

<p>Q44: What is your annual household income from all sources?</p> <p>1. Less than \$25K</p> <p>2. \$25K to less than \$50K</p> <p>3. \$50K to less than \$75K</p> <p>4. \$75k to less than \$100k</p> <p>5. \$100k or more</p>	<p>1: 196 (18.0%)</p> <p>2: 264 (24.3%)</p> <p>3: 204 (18.8%)</p> <p>4: 150 (13.8%)</p> <p>5: 153 (14.1%)</p> <p>7: Don't know/Not sure: 35 (3.2%)</p> <p>9: Refused: 86 (7.9%)</p>
<p>Q2: During the last year, in a typical 7-day week, about how many miles did you drive?</p> <p>11. None</p> <p>12. Less than 20 miles</p> <p>13. 20-99 miles</p> <p>14. 100-199 miles</p> <p>15. 200-499 miles</p> <p>16. 500-999 miles</p> <p>17. 1000 miles or more</p>	<p>11: 3 (0.3%)</p> <p>12: 78 (7.2%)</p> <p>13: 351 (32.3%)</p> <p>14: 246 (22.6%)</p> <p>15: 231 (21.2%)</p> <p>16: 55 (5.1%)</p> <p>17: 58 (5.3%)</p> <p>77: 22 (2.0%)</p> <p>System: 44 (4.0%)</p>

Table A-1 continued: Public Opinions to the Identified 11 High-level Goals, with the Inclusion of Demographic Information (adopted from Albrecht et al., 2013)

32. What types of vehicles do you drive? (Check all that apply)	1: 778 (71.5%)
1. Car	2: 562 (51.7%)
2. Pickup truck or van	3: 65 (6.0%)
3. Motorcycle	4: 51 (4.7%)
4. Commercial vehicle	5: 143 (13.1%)
5. Other	7: 0
7. Don't know/Not sure	8: 23 (2.1%)
8. No vehicles	9: 1 (0.1%)
9. Refused	
33. Do you have a valid motor vehicle driver's license?	1: 1041 (95.7%)
1. Yes	2: 41 (3.8%)
2. No, do not have a license	3: 6 (0.6%)
3. No, current license suspended	

APPENDIX B: OTHER RESULTS

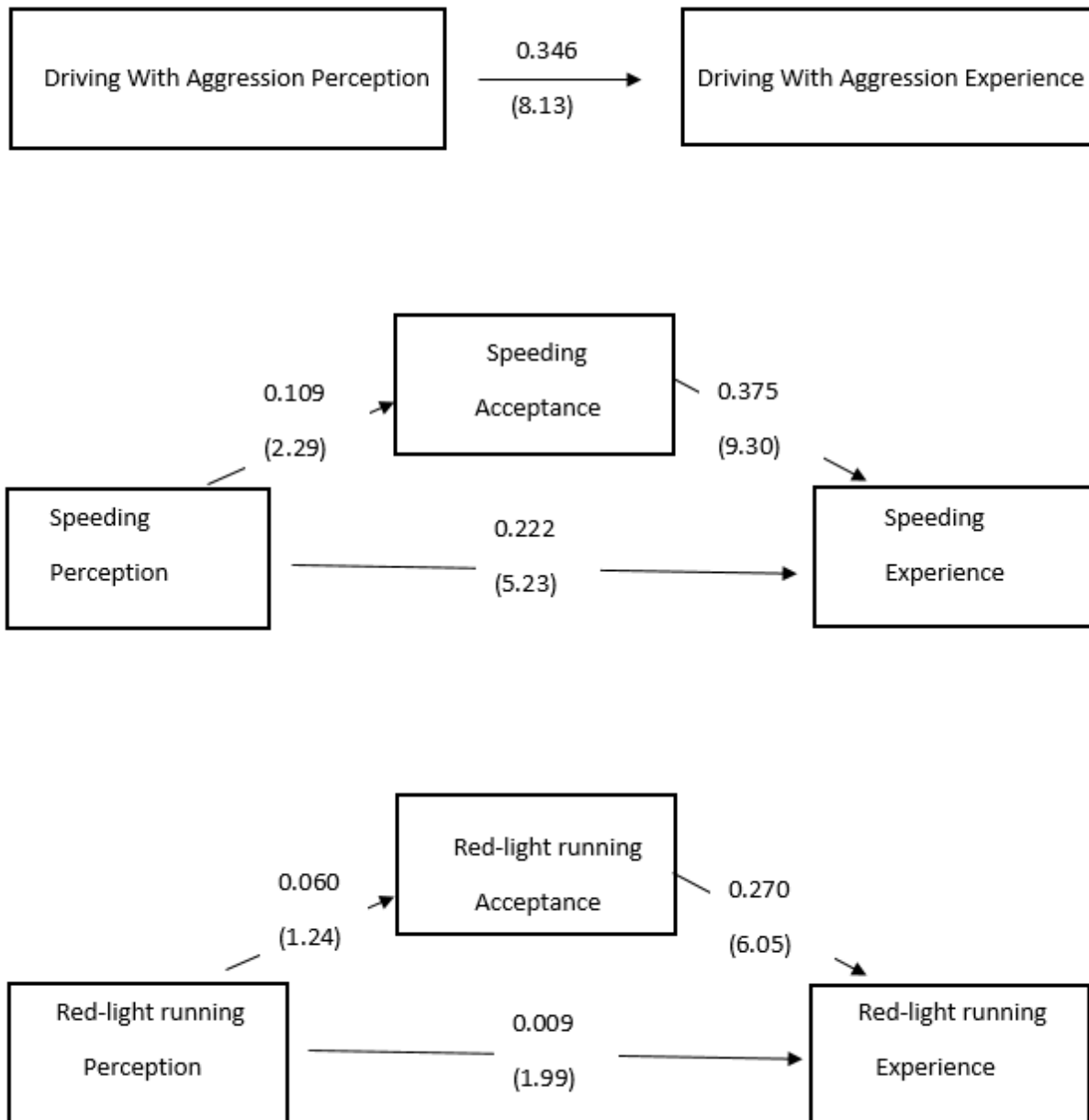

Figure B.1 The estimated path coefficients and t-statistics of each aggressive behavior for male

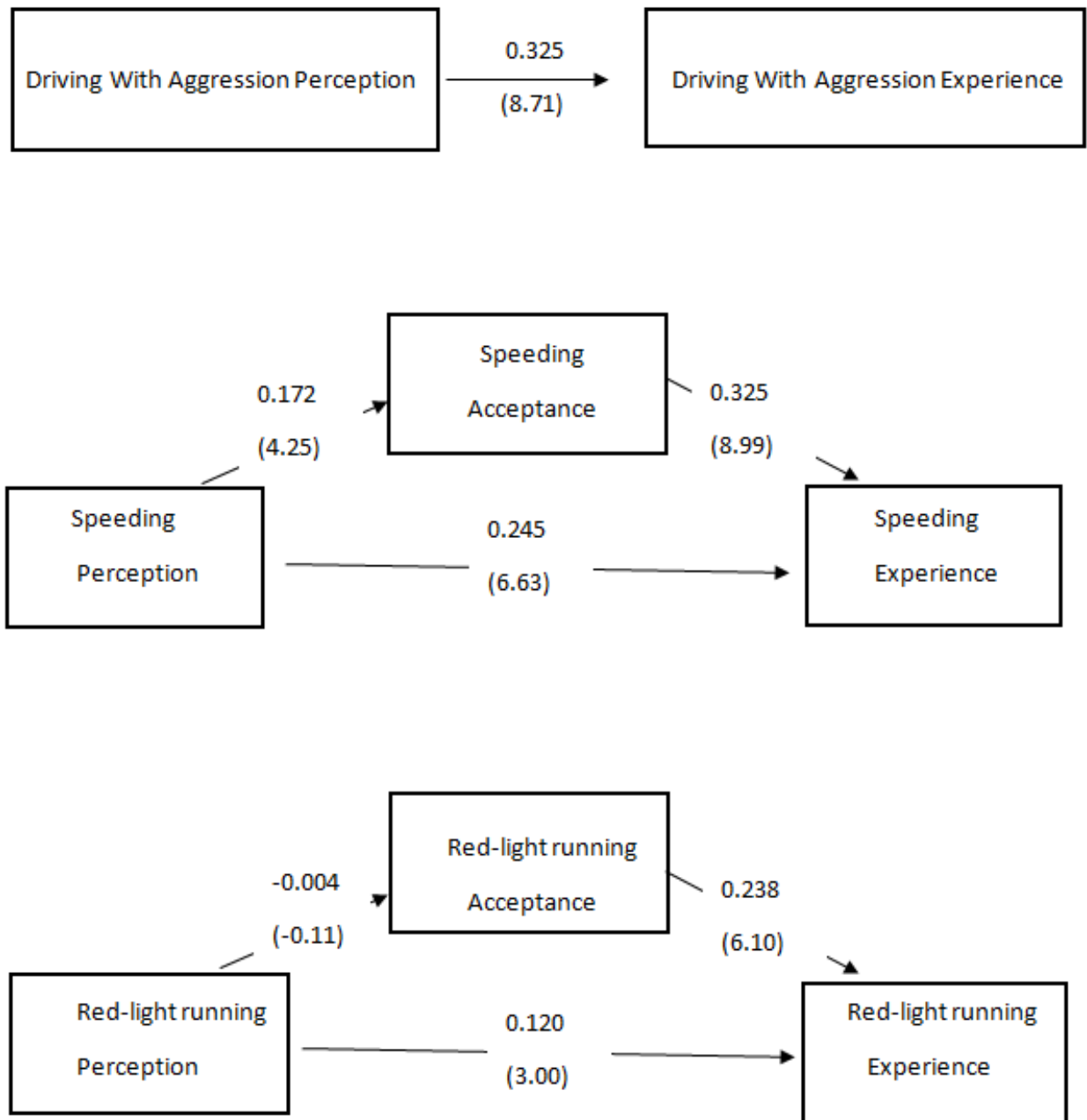

Figure B.2 The estimated path coefficients and t-statistics of each aggressive behavior for female

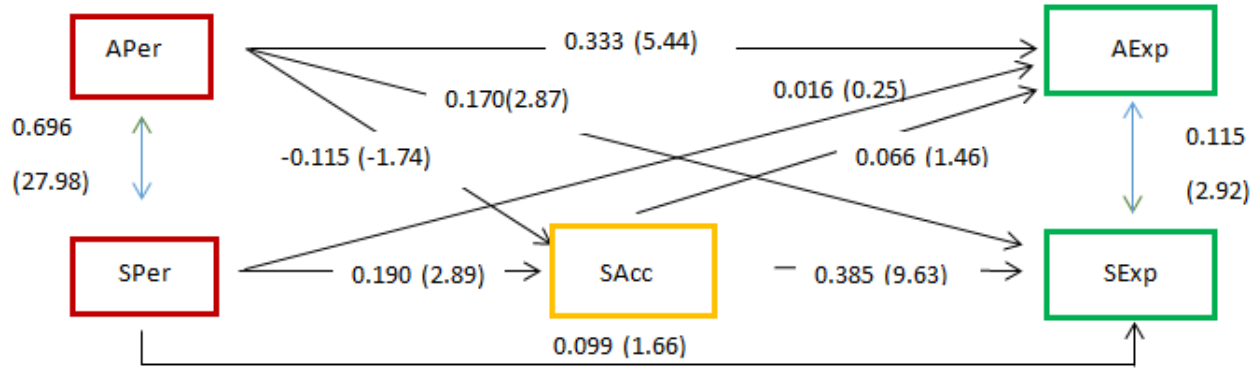

Figure B.3 Male's theoretical model of proposed relationships between perception, acceptance, and experience with DWA and speeding. N=431, $\chi^2_0 = 0$, RMSR = 0, AGFI = 1, CFI = 1.

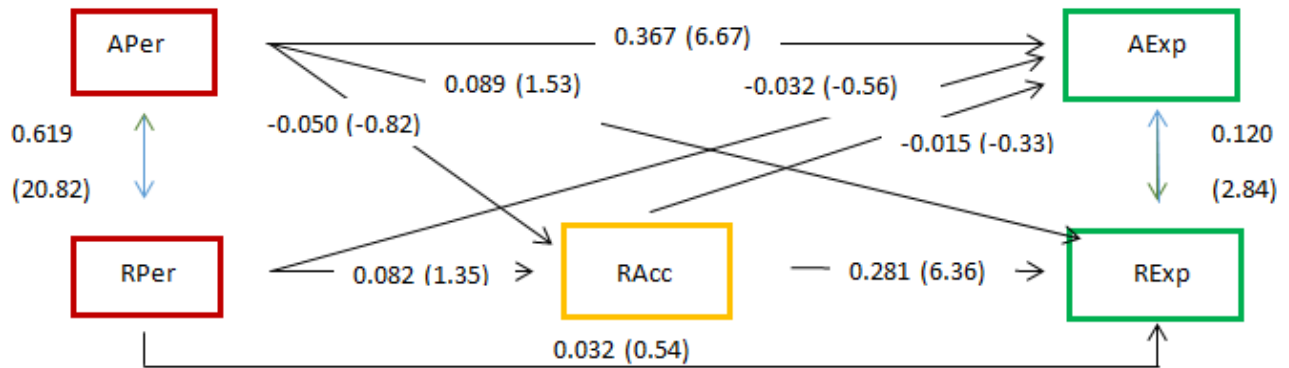

Figure B.4 Male's theoretical model of proposed relationships between perception, acceptance, and experience with DWA and RLR. N=433, $\chi^2_0 = 0$, RMSR = 0, AGFI = 1, CFI = 1.

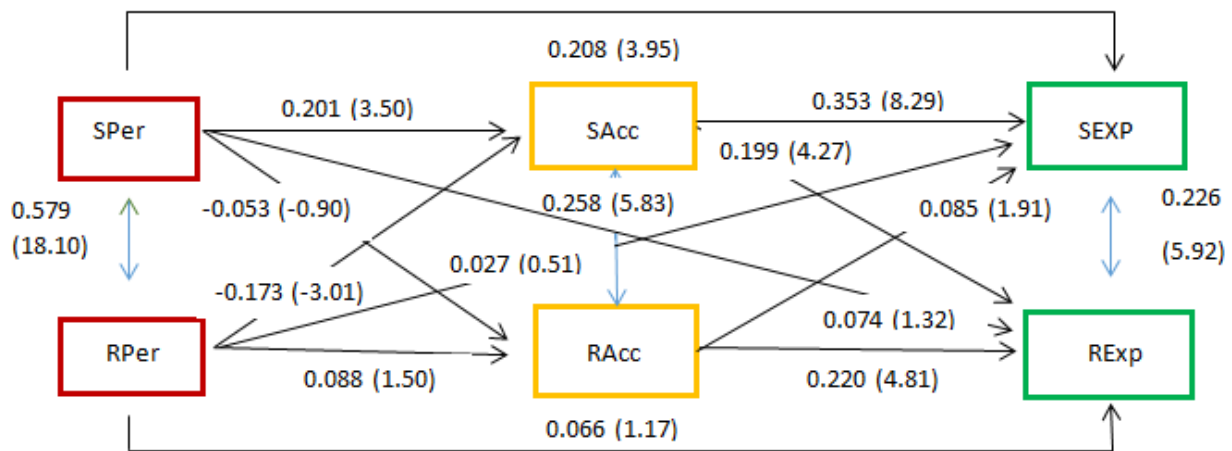

Figure B.5 Male's theoretical model of proposed relationships between perception, acceptance, and experience with speeding and RLR. N=432, $\chi^2_0 = 0$, RMSR = 0, AGFI = 1, CFI = 1.

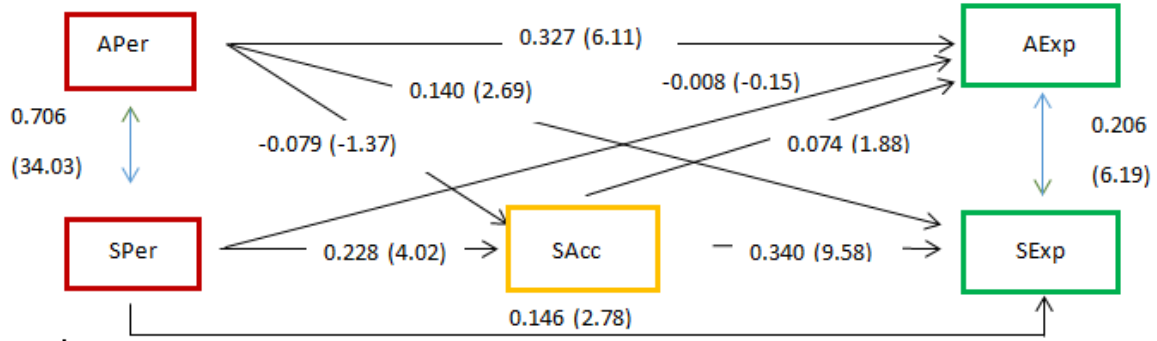

Figure B.6 Female's theoretical model of proposed relationships between perception, acceptance, and experience with DWA and speeding. N=585, $\chi^2_0 = 0$, RMSR = 0, AGFI = 1, CFI = 1.

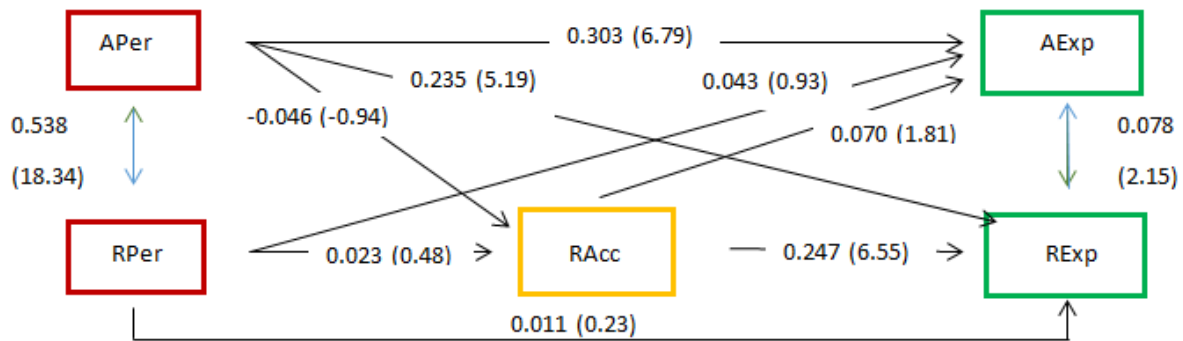

Figure B.7 Female's theoretical model of proposed relationships between perception, acceptance, and experience with DWA and RLR. N=588, $\chi^2_0 = 0$, RMSR = 0, AGFI = 1, CFI = 1.

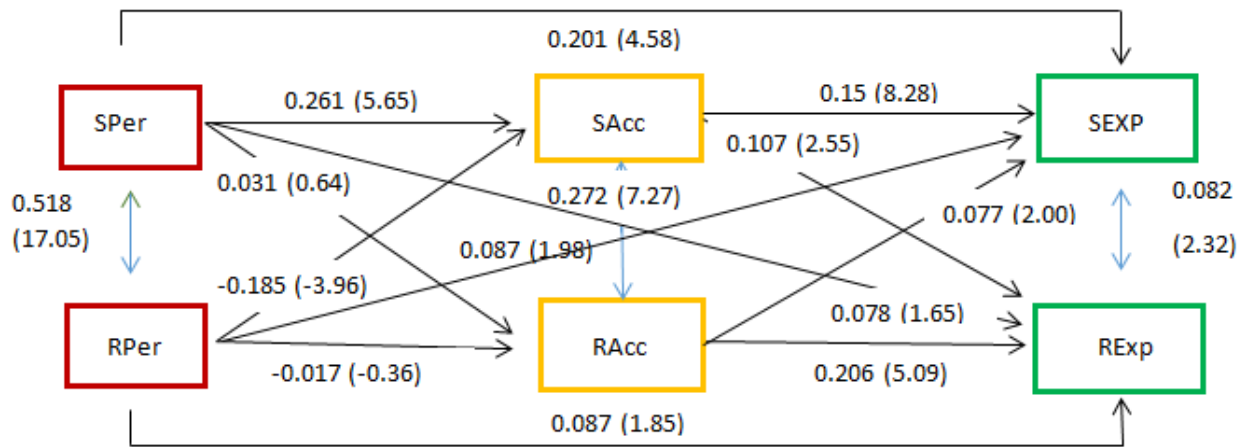
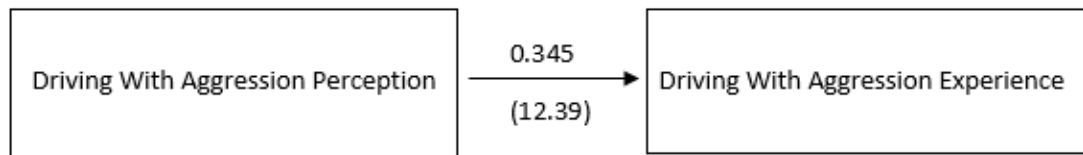
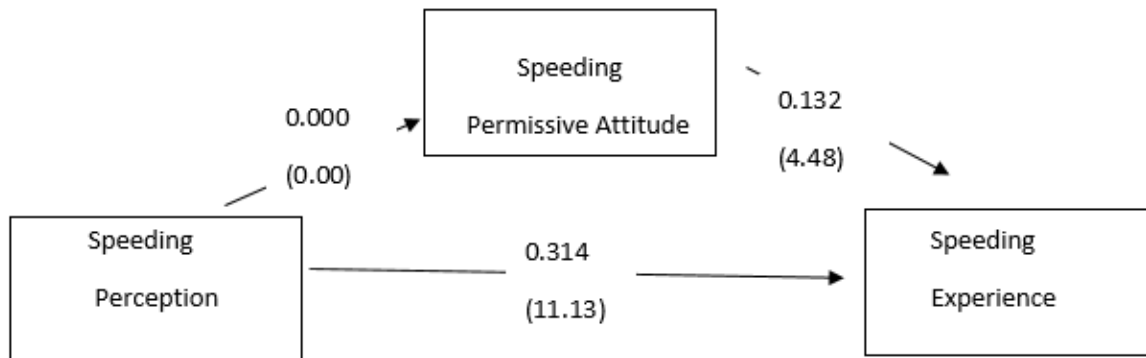

Figure B.8 Female's theoretical model of proposed relationships between perception, acceptance, and experience with speeding and RLR. N=581, $\chi^2_0 = 0$, RMSR = 0, AGFI = 1, CFI = 1.



The decomposition of effects for Driving with Aggression: $0.345 (t=12.39) = 0.345 (t=12.39) + 0$



The decomposition of effects for Speeding: $0.314 (t= 11.03) = 0.314 (t=11.03) + 0$

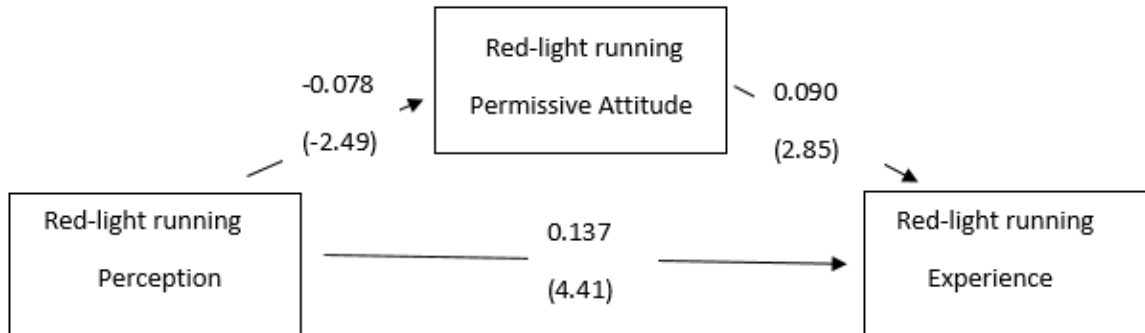

The decomposition of effects for Red-light Running: $0.130 (t=4.18) = 0.137 (t=4.41) + (-0.007) (t= -1.87)$

Figure B.9 The estimated path coefficient (t-statistics) and the decomposition of total effects for each aggressive behavior (permissive attitude mediation)